

MUNCHKIN  
**CONTENDER**

**Gas-fired  
Hot Water  
Circulating  
Heater**

**Installation  
Manual**

- *Installation*
- *Startup*
- *Maintenance*
- *Parts*



**H E A T T R A N S F E R P R O D U C T S , I N C .**

**⚠ WARNING**

This manual must only be used by a qualified heating installer/service technician. Read all instructions in this manual before installing. Perform steps in the order given. Failure to comply could result in severe personal injury, death or substantial property damage.

**⚠ WARNING**

**If the information in this manual is not followed exactly, a fire or explosion may result causing property damage, personal injury or loss of life.**

Do not store or use gasoline or other flammable vapors and liquids in the vicinity of this or any other appliance.

**WHAT TO DO IF YOU SMELL GAS**

- Do not try to light any appliance.
- Do not touch any electrical switch: do not use any phone in your building.
- Immediately call your gas supplier from a neighbor's phone. Follow the gas supplier's instructions.
- If you cannot reach your gas supplier, call the fire department. Installation and service must be performed by a qualified installer, service agency or the gas supplier.
- Installation and service must be performed by a qualified installer, service agency or the gas supplier.

# CONTENTS

**Part 1 – Product and Safety Information. . . . . 4,5**

**Part 2 – How The Heater Operates. . . . . 6-8**

**Part 3 – Prepare Heater Location . . . . . 8-11**

- A. Installations Must Comply With:
- B. Before Locating Heater
- C. Clearances for Service Access
- D. Residential Garage Installation
- E. Air Intake and Exhaust Vent
- F. Prevent Combustion Air Contamination
- G. When Removing an Appliance from an Existing Common Vent System

**Part 4 – Prepare Munchkin Contender Heater . . . . . 11-12**

- A. Remove Munchkin Contender Heater from Box
- B. Placing Wall-Mounted Munchkin Contender
- C. Munchkin Contender Wall Mounting Instruction
- D. Installation Steps

**Part 5 – Munchkin Contender Piping . . . . . 13-24**

- Contender Piping Details . . . . . 18-24
- A. Relief Valve
- B. General Piping Information
- C. Separate Low Water Cutoff
- D. Backflow Preventer
- E. System Water Piping Methods
- F. Circulators
- G. Hydronic Piping with Circulators, Zone Valves and Multiple Heaters
- H. Circulator Sizing
- I. Fill and Purge Heating System
- J. Zoning with Zone Valves
- K. Zoning with Circulators
- L. Multiple Heaters
- M. Contender Piping Details

**Part 6 – Contender Piping with Optional Vision 1 System . . . . . 25-35**

- Contender Piping Details With Vision I System. . . . . 26-35
- A. Vision 1 System Piping
- B. Zoning with Zone Valves Using Vision I
- C. Zoning with Circulators Using Vision I
- D. Contender Piping Details with the Vision I System

**Part 7 – Venting Combustion Air And Condensate Removal. . . . . 36-44**

- Venting Details. . . . . 43,44
- A. Installing Exhaust Vent and Intake Air Vent
- B. General
- C. Approved Materials for Exhaust Vent and Intake Air Vent
- D. Exhaust Vent and Intake Air Vent Pipe Location.
- E. Exhaust Vent and Intake Air Vent Sizing

**CONTENTS (CONT'D)**

- F. Exhaust Vent and Intake Air Pipe Installation.
- G. Heater Removal from a Common Vent System
- H. Condensate Removal System
- I. Diagrams for Side Wall Venting

**Part 8 – Gas Piping . . . . . 45,46**

- A. Gas Connection
- B. Gas Piping
- C. Gas Table
- D. Dungs Gas Valve

**Part 9 – Field Wiring. . . . . 47-49**

- A. Installation Must Comply With
- B. Field Wiring
- C. Line Voltage Wiring
- D. Thermostat

**Part 10 – Field Wiring – Vision 1 Option. . . . . 50**

**Part 11 – Start Up Preparation . . . . . 51-53**

- A. Check/Control Water Chemistry
- B. Freeze Protection (when used)
- C. Fill and Test Water System
- D. Purge Air from Water System
- E. Check for Gas Leaks
- F. Check Thermostat Circuit(s)
- G. Condensate Removal
- H. Final Checks Before Starting The Munchkin Contender

**Part 12 – Start-Up Procedure . . . . . 53-55**

- A. Operating Instructions
- B. Adjusting the Set Point
- C. Status Menu
- D. Test Mode

**Part 13 – Start-Up Procedures With The Vision 1 Option . . . . . 55-56**

- A. Programming the Vision I Option
- B. Vision I Program Access
- C. Vision I Program Navigation

**Part 14 – Troubleshooting. . . . . 59-61**

- A. Munchkin Error Code
- B. Heater Error
- C. Heater Fault

**Part 15 – Maintenance. . . . . 61-65**

- A. Maintenance Procedures
- B. Combustion Chamber Coil Cleaning Instructions

**Part 16 – Heater Inspection and Maintenance Start-Up Charts . . . . . 66-68**

## PART 1: PRODUCT AND SAFETY INFORMATION

### SPECIAL ATTENTION BOXES

The following defined terms are used throughout this manual to bring attention to the presence of hazards of various risk levels or to important information concerning the product.

#### DEFINITIONS

##### **DANGER**

**DANGER** indicates an imminently hazardous situation which, if not avoided, will result in death or serious injury.

##### **CAUTION**

**CAUTION** Indicates a potentially hazardous situation which, if not avoided, may result in minor or moderate injury.

##### **WARNING**

**WARNING** indicates a potentially hazardous situation which, if not avoided, could result in death or serious injury.

##### **CAUTION**

**CAUTION** used without the safety alert symbol indicates a potentially hazardous situation which, if not avoided, may result in property damage.

#### NOTICE

*Heat Transfer Products, Inc., reserves the right to make product changes or updates without notice and will not be held liable for typographical errors in literature.*

**PART 1: PRODUCT AND SAFETY INFORMATION (CONT'D)**

**⚠ WARNING**

**Installer** — Read all instructions in this manual, and Munchkin Contender Venting section, before installing. Perform steps in the order given.

**User** — This manual is for use only by a qualified heating installer/service technician. Refer to User's Information Manual for your reference.

**User** — Have this heater serviced/inspected by a qualified service technician annually.

Failure to comply with the above could result in severe personal injury, death or substantial property damage.

**⚠ WARNING**

Failure to adhere to the guidelines on this page can result in severe personal injury, death or substantial property damage.

**⚠ WARNING**

**WHAT TO DO IF YOU SMELL GAS**

- Do not try to light any appliance.
- Do not touch any electric switch; do not use any phone in your building.
- Immediately call your gas supplier from a neighbor's phone. Follow the gas suppliers' instructions.
- If you cannot reach your gas supplier, call the fire department.

**Before Installing**

**WHEN SERVICING THE MUNCHKIN CONTENDER**

- To avoid electric shock, disconnect electrical supply before performing maintenance.
- To avoid severe burns, allow heater to cool before performing maintenance.

**MUNCHKIN CONTENDER OPERATION**

- Do not block flow of combustion or ventilation air to heater.
- Should overheating occur or gas supply fail to shut off, do not turn off or disconnect electrical

supply to circulator. Instead, shut off the gas supply at a location external to the appliance.

- Do not use this heater if any part has been under water. Immediately call a qualified service technician to inspect the heater and to replace any part of the control system and any gas control that has been under water.

**HEATER WATER**

The piping and components connected to the Munchkin Contender for space the heating application shall be suitable for use with potable water. Toxic chemicals, such a used for boiler treatment, shall not be introduced into the potable water when the Munchkin Contender is used for space heating.

When the Munchkin Contender is used to supply potable water, it shall not be connected to any heating system or component(s) previously used with a non-potable water heating appliance.

**⚠ WARNING**

**NEVER use any toxic chemical, including automotive or standard glycol antifreeze or ethylene glycol made for hydronic (non-potable) systems. These chemicals are poisonous if consumed and can cause injury or death. These chemicals can also attack gaskets and seals in water heaters.**

- If you have an old system with cast iron radiators, thoroughly flush the system (without heater connected) to remove sediment. The high-efficiency heat exchanger can be damaged by build-up or corrosion due to sediment.
- Do not use petroleum-based cleaning or sealing compounds in heater system. Gaskets and seals in the system may be damaged. This can result in substantial property damage.
- Do not use "homemade cures" or "boiler patent medicines." Substantial property damage, damage to heater, and/or serious personal injury may result.
- Continual fresh make-up water will reduce the heater life. Mineral buildup in heat exchanger reduces heat transfer, overheats the stainless steel heat exchanger, and causes failure. Addition of oxygen carried in by make-up water

## PART 1: PRODUCT AND SAFETY INFORMATION (CONT'D)

can cause internal corrosion in system components. Leaks in heater or piping must be repaired at once to prevent make-up water.

### WINTERIZING THE MUNCHKIN CONTENDER

To winterize the Munchkin Contender, drain the entire system, then apply air pressure to the drain valve and allow air and water to escape from the purge valve (see piping instructions). Once you have evacuated all of the water that is possible, you will then need to pump in the non toxic propylene glycol food grade NSF® listed antifreeze (SAFE-T-THERM [www.houghton.com](http://www.houghton.com) or PARATHERM [www.paratherm.com](http://www.paratherm.com)). Try to calculate the entire volume of the piping system to insure the entire system will be adequately protected. Consult the glycol manufacturer for mixture % recommendations to adequately protect the system for the local climate of the installation.

With a pump, fill the system with the non-toxic propylene glycol food grade NSF® listed antifreeze, allowing the air and remaining water to escape from the purge valve. Once the stream coming out of the purge valve matches the color of the non toxic propylene glycol food grade NSF® listed antifreeze, the system should be adequately filled. It is recommended at this point to start any circulation pump and allow the

system to circulate for at least 30 minutes to completely blend any trapped water that might be in the system with the NSF® listed solution. At this point it is suggested that you check the concentration of NSF® antifreeze to be sure that protection is adequate. Consult the glycol manufacturer for specific instructions on the concentration % as well as the freeze and burst protection methods.

### FREEZE PROTECTION FLUIDS

#### CAUTION

**NEVER use automotive or standard glycol antifreeze, even ethylene glycol made for hydronic systems. Use only inhibited propylene glycol solutions, which are specifically formulated for hydronic systems. Ethylene glycol is toxic and can attack gaskets and seals used in hydronic systems.**

#### CAUTION

**Consider piping and installation when determining heater location. Any claims for damage or shortage in shipment must be filed immediately against the transportation company by the consignee.**

## PART 2: HOW THE MUNCHKIN CONTENDER OPERATES

**Munchkin Contender Condensing Technology** is an intelligent system that delivers highly efficient hydronic heating, while maximizing efficiency by measuring the Data Parameters of your heating system.

### 1. Stainless Steel Heat Exchanger

The highly efficient durable Munchkin Contender Stainless Steel Heat Exchanger is designed to take the colder return water from the system and extract the last bit of energy before it is exhausted. The heat exchanger design is separated by an internal baffle which diverts the exhaust gas through the primary heat exchanger into the secondary heat exchanger where the colder return water extracts the last residual heat.

### 2. Modulating Combustion System

Modulation during the central heating operation is based on the supply temperature. The set point used for the control depends upon the programmed central heating curve. The slope of the heating curve can be changed by the installer of the Munchkin Contender in the sense that both turning points of the curve can be moved. The control monitors the system to regulate the output of the burner during operation to match the system demand. This increase in efficiency allows for substantial fuel savings.

### 3. Gas Valve

The gas valve senses suction from the blower, allowing gas to flow only if the gas valve is

## PART 2: HOW THE MUNCHKIN CONTENDER OPERATES (CONT'D)

powered and combustion air is flowing.

### 4. Swirl Plate System

The Swirl Plate on the gas valve controls the air and gas flow into the burner, which will assure better mixing for improved combustion.

### 5. Supply water temperature sensor

This sensor monitors heater output water temperature (system supply). The control module adjusts the heater firing rate so the outlet temperature is correct.

### 6. Return water temperature sensor

This sensor monitors the return water temperature (system return). The control module reduces or increases heater input, depending on how close the return water temperature is to the outlet water temperature.

### 7. Temperature and pressure gauge

Allows the user to monitor the systems temperature and pressure.

### 8. Control

The integrated control system monitors the return and supply water and regulates the fan speed to regulate the unit's BTU output. This allows the unit to only deliver the amount of heated energy required and nothing more!

### 9. Flue pipe adapter

The flue pipe adapter may be positioned so that the installer is able to find a position that will best facilitate the exhaust and combustion air pipe connections with the least number of elbows even in the most challenging applications.

### 10. Burner

Made with metal fiber and stainless steel construction, the burner uses pre-mixed air and gas and provides a wide range of firing rates.

### 11. Electrical field connections with terminal strips

The electrical cover plate allows access the line voltage terminal strip and the low voltage terminal strip. Attach line voltage conduits to the three holes at the right of the line voltage terminal strip for power, CH pump and DHW

pump. Route low voltage wires through the opening to the left of the low voltage terminal strip. (See Field Wiring Instructions Part 9.)

### 12. Condensate drain connection

This is a condensing high efficiency appliance, therefore this unit has a condensate removal system. Condensate is nothing more than water vapor, derived from the combustion products, similar to an automobile when it is initially started. It is very important that the condensate line is sloped away from the heater and down to a suitable inside drain, if the condensate outlet on the Munchkin Contender is lower than the drain, you must use a condensate removal pump (kit p/n 554200 available from Heat Transfer Products, Inc.) A condensate filter, if required by local authorities can be made up of lime crystals, marble or phosphate chips and will neutralize the condensate. This can be done in the field by the installer or you may purchase one from Heat Transfer Products, Inc. (P/N N1100). It is also very important that the condensate line is not exposed to freezing temperatures or any other type of blockage. Plastic tubing should be the only material used for the condensate line. Steel, brass, copper or others will be subject to corrosion or deterioration. A second vent may be necessary to prevent condensate line vacuum lock if a long horizontal run is used. Also, an increase in pipe size may be necessary to drain properly. Support of the condensation line may be necessary to avoid blockage of the condensate flow.

### 13. Spark ignition

The burner flame is ignited by applying a high voltage to the system spark electrode. This causes a spark from electrode to ground.

### 14. The Vision 1 Optional System

The Vision I System will allow the installing contractor to take the highly efficient modulating Munchkin Contender and make it even more efficient by controlling the temperature delivered to the central heating circuits based on the outside temperature. The Vision I system is also a two temperature system, one temperature for central heating and the other temperature to the Super Stor Ultra Indirect water heater. This allows the user to increase the temperature supplied to the



## PART 2: HOW THE MUNCHKIN CONTENDER OPERATES (CONT'D)

Super Stor Ultra Indirect Water Heater to get a fast recovery by prioritizing the flow at a higher temperature than may be needed for the central heating circuits (this will require two separate circulators). You must follow the piping, wiring and programming instructions

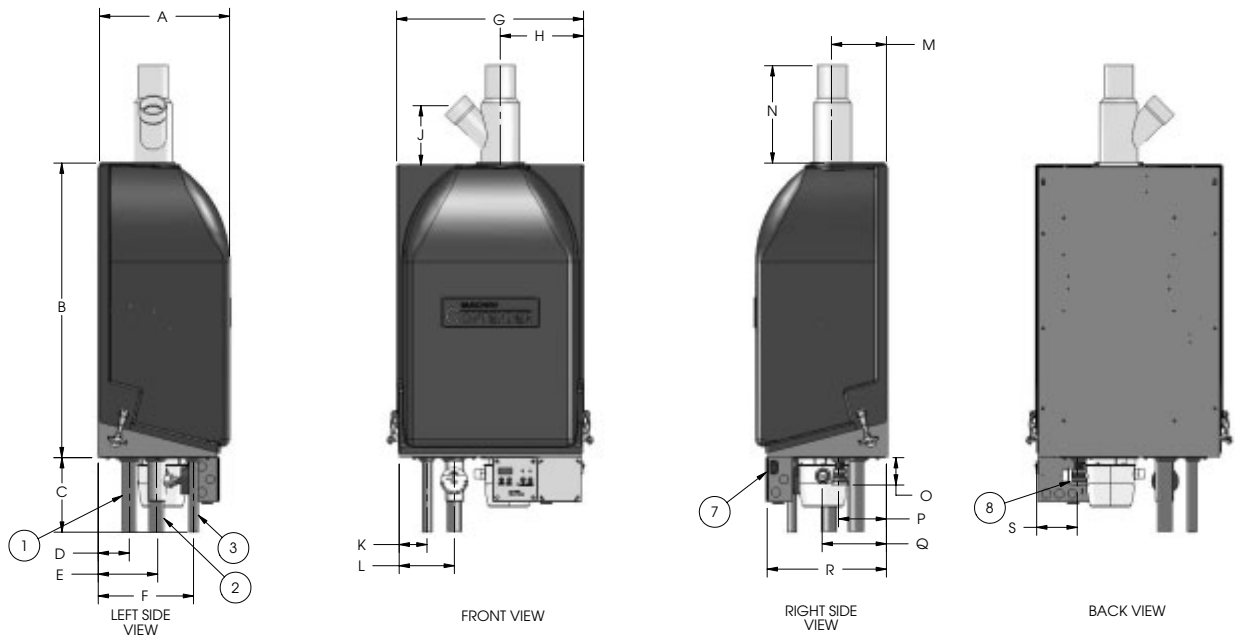
located in the Vision One section of this manual. Optional kit consists of the following

- Outdoor sensor – 7250P-319
- Indirect tank sensor – 7250P-325

- ① SYSTEM RETURN
- ② SYSTEM SUPPLY
- ③ SYSTEM RELIEF

- ④ COMBUSTION AIR INLET CONNECTION
- ⑤ EXHAUST VENT CONNECTION
- ⑥ CONDENSATE CUP/DRAIN ASSEMBLY

- ⑦ ELECTRICAL BOX/CONTROL PANEL
- ⑧ GAS LINE CONNECTION



MUNCHKIN CONTENDER HEATER DIMENSIONS AND SPECIFICATIONS																													
MODEL NUMBER	BTU/HR INPUT LOW FIRE	BTU/HR INPUT HIGH FIRE	A	B	C	D	E	F	G	H	J	K	L	M	N	O	P	Q	R	S	COMBUSTION AIR INLET/EXHAUST VENT CONNECTION SIZE	SYSTEM RELIEF PIPE SIZE	SYSTEM SUPPLY/ SYSTEM RETURN/ PIPE SIZE	GAS LINE CONN.	HEATER WATER VOLUME	ENERGY FACTOR EF 3	DOE EFF. AFUE 1	LOW WATER EFF. LTAE 2	APPROX. SHIPPING WEIGHT
MC50	18,000	50,000	12.50	27.50	7.00	2.75	5.25	9.00	17.25	7.75	5.50	2.75	5.25	5.00	9.00	2.75	4.00	6.50	10.25	4.00	2.00	.75	1.25	.75	.58	.91	92%	98%	71 LBS
MC80	19,000	80,000	12.50	27.50	7.00	2.75	5.25	9.00	17.25	7.75	6.50	2.75	5.25	5.00	9.00	2.75	5.25	6.50	10.25	4.00	2.00	.75	1.25	.75	.67	.93	92%	98%	74 LBS
MC99	44,000	99,000	13.50	27.50	7.00	2.75	6.50	10.25	17.25	7.75	5.50	2.75	5.25	6.00	9.00	2.75	7.75	6.50	11.25	4.00	2.00	.75	1.25	.75	.96	.95	93%	98%	84 LBS
MC120	44,000	120,000	13.50	27.50	7.00	2.75	6.50	10.25	17.25	7.75	5.50	2.75	5.25	6.00	9.00	2.75	7.75	6.50	11.25	4.00	2.00	.75	1.25	.75	.96	.95	92%	98%	84 LBS

1. Tested by Heat Transfer Products to the ANSI/ASHRAE 103
2. Tested by Heat Transfer Products to the ANSI/ASHRAE Standard 103 with 90° return and 110° supply water
3. Tested by Heat Transfer Products to the 10 CFR 430.23 2005

## PART 3: PREPARE MUNCHKIN CONTENDER LOCATION

### A. INSTALLATIONS MUST COMPLY WITH:

- Local, state, provincial, and national codes, laws, regulations and ordinances.
- National Fuel Gas Code, ANSI Z223.1 – latest edition.
- National Electrical Code.
- For Canada only: B149.1 or B149.2 Installation Code, CSA C22.1 Canadian Electrical Code Part 1 and any local codes.

**PART 3: PREPARE MUNCHKIN CONTENDER LOCATION (CONTINUED)**

**NOTICE**

The Munchkin Contender Heater gas manifold and controls met safe lighting and other performance criteria when heater underwent tests specified in ANSI Z21.10.3 — latest edition.

**BEFORE LOCATING THE MUNCHKIN CONTENDER**

1. Check for nearby connection to:
  - System water piping
  - Venting connections
  - Gas supply piping
  - Electrical power
2. Check area around heater. Remove any combustible materials, gasoline and other flammable liquids.

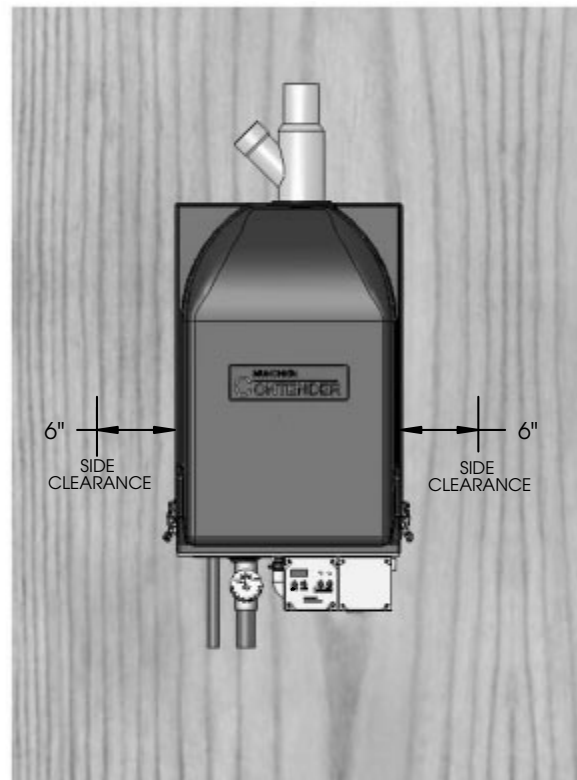
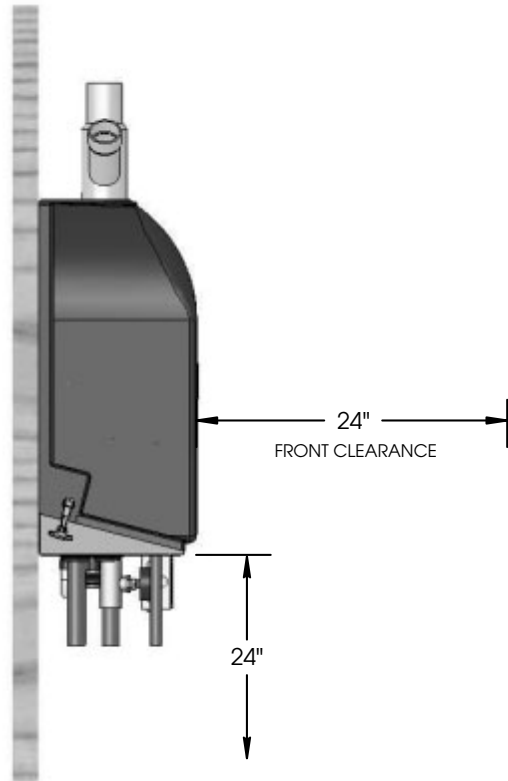
**⚠ WARNING**

Failure to keep heater area clear and free of combustible materials, gasoline and other flammable liquids and vapors can result in severe personal injury, death or substantial property damage.

3. The Munchkin Contender must be installed so that gas control system components are protected from dripping or spraying water or rain during operation or service.
4. If the new Munchkin Contender is to replace an existing heater, check for and correct any *existing* system problems such as:
  - System leaks.
  - Incorrectly-sized expansion tank.
  - Lack of freeze protection in heating water causing system and heater to freeze and leak.
  - Excessive glycol which will affect the heater system operation.

**C. CLEARANCES FOR SERVICE ACCESS**

1. See Figure 3-1 for recommended service clearances. If you do not provide minimum clearances shown, it might not be possible to service the heater without removing it from the space.



**Figure 3-1: Clearances required**

## PART 3: PREPARE MUNCHKIN CONTENDER LOCATION (CONTINUED)

### **WARNING**

The space must be provided with combustion/ventilation air openings correctly sized for all other appliances located in the same space as the Munchkin Contender heater. The heater cover must be securely fastened to the heater to prevent heater from drawing air from inside the heater room. This is particularly important if the heater is located in the same room as other appliances. Failure to comply with the above warnings could result in severe personal injury, death or substantial property damage.

### D. RESIDENTIAL GARAGE INSTALLATION

#### Precautions

Take the following special precautions when installing the Munchkin Contender in a residential garage. If the heater is located in a residential garage, per ANSI Z223.1, paragraph 5.1.9:

- Mount the heater with a minimum of 18 inches above the floor of the garage to the bottom of the heater to ensure the burner and ignition devices will be no less than 18 inches above the floor.
- Locate or protect the heater so it cannot be damaged by a moving vehicle.

### E. EXHAUST VENT AND INTAKE AIR VENT

The Munchkin Contender requires a special vent system, designed for pressurized venting. Munchkin Contenders are rated ANSI Z21.10.3 Category IV (pressurized vent, likely to condense in the vent).

You must also install air intake piping from outside to the heater flue adaptor. The resultant installation is categorized as direct vent (sealed combustion). **Note: To prevent combustion air contamination see Table 3-2 in this section when considering exhaust vent and intake air vent termination.**

Intake and exhaust must terminate near each other and may be vented vertically through the roof or out a side wall. The intake and exhaust venting methods are detailed in the Venting Section. Do not attempt to install the Munchkin Contender Heater using any other means. Be sure to locate the heater such that the air intake and exhaust vent piping can be routed through

the building and properly terminated. The air intake and exhaust vent piping lengths, routing and termination method must all comply with the methods and limits given in the Venting section.

### F. PREVENT COMBUSTION AIR CONTAMINATION

Install intake air piping for the Munchkin Contender as described in the Venting section. Do not terminate exhaust in locations that can allow contamination of intake air.

### **WARNING**

You must pipe outside air to the heater air intake. Ensure that the intake air will not contain any of the contaminants below. Contaminated air will damage the heater, resulting in possible severe personal injury, death or substantial property damage. For example, do not pipe intake air vent near a swimming pool. Also avoid areas subject to exhaust fumes from laundry facilities. These areas will always contain contaminants.

Table 3-2: Corrosive contaminants and sources

Products to avoid
Spray cans containing fluorocarbons
Permanent wave solutions
Chlorinated waxes/cleaners
Chlorine-based swimming pool chemicals
Calcium chloride used for thawing
Sodium chloride used for water softening
Refrigerant leaks
Paint or varnish removers
Hydrochloric acid/muriatic acid
Cements and glues
Antistatic fabric softeners used in clothes dryers
Chlorine-type bleaches, detergents, and cleaning solvents found in household laundry rooms
Adhesives used to fasten building products and other similar products
Areas likely to have contaminants
Dry cleaning/laundry areas and establishments
Swimming pools
Metal fabrication plants
Beauty shops
Refrigeration repair shops
Photo processing plants
Auto body shops
Plastic manufacturing plants
Furniture refinishing areas and establishments
New building construction
Remodeling areas
Garages and workshops

## PART 3: PREPARE MUNCHKIN CONTENDER LOCATION (CONTINUED)

### G. WHEN REMOVING AN EXISTING HEATER FROM AN EXISTING COMMON VENT SYSTEM

#### **⚠ DANGER**

Do not install the Munchkin Contender heater into a common vent with any other appliance. This will cause flue gas spillage or appliance malfunction, resulting in possible severe personal injury, death or substantial property damage.

#### **⚠ WARNING**

Failure to follow all instructions can result in flue gas spillage and carbon monoxide emissions, causing severe personal injury or death.

At the time of removal of an existing heater, the following steps shall be followed with each appliance remaining connected to the common venting system placed in operation, while the other appliances remaining connected to the common venting system are not in operation.

- a. Seal any unused openings in the common venting system.
- b. Visually inspect the venting system for proper size and horizontal pitch and determine there is non blockage or restriction, leakage, corrosion and other deficiencies which could cause an unsafe condition.
- c. Insofar as is practical, close all building doors and windows and all doors between the space

in which the appliances remaining connected to the common venting system are located and other spaces of the building. Turn on clothes dryers and any appliance not connected to the common venting system. Turn on any exhaust fans, such as range hoods and bathroom exhausts, so they will operate at maximum speed. Do not operate a summer exhaust fan. Close fireplace dampers.

- d. Place in operation the appliance being inspected. Follow the lighting instructions. Adjust thermostat so appliance will operate continuously.
- e. Test for spillage at draft hood opening after 5 minutes of main burner operation. Use the flame of a match or candle, or smoke from a cigarette, cigar, or pipe.
- f. After it has been determined that each appliance remaining connected to the common venting system properly vents when tested as outlined herein, return doors, windows, exhaust fans, fireplace dampers, and any other gas-burning appliance to their previous conditions of use.
- g. Any improper operation of the common venting system should be corrected so the installation conforms with the National Fuel Gas Code, ANSI Z223.1 — latest edition. Correct by resizing to approach the minimum size as determined using the appropriate tables in Table 13 of NFPA54 ANSI Z223.1 2006 of that code. Canadian installations must comply with B149.1 or B149.2 Installation Code.

## PART 4: PREPARE MUNCHKIN CONTENDER HEATER

#### **CAUTION**

Cold weather handling — If heater has been stored in a very cold location (below 0°F) before installation, handle with care until the plastic components come to room temperature.

### A. REMOVE MUNCHKIN CONTENDER HEATER FROM BOX

1. The Munchkin Contender is easy to handle.

Care must be taken to place it in a safe location prior to installation on the wall to prevent damage to the bottom mechanical connections.

### B. PLACING THE WALL-MOUNTED MUNCHKIN CONTENDER HEATER

Munchkin Contender Heaters are wall mounted. Use only the Munchkin Contender Heater wall mounting instructions included in installation envelope.

**PART 4: PREPARE MUNCHKIN CONTENDER (CONTINUED)**

**⚠ WARNING**

The wall must be capable of carrying the weight of the heater and its related components. The weights of the heater are approximately:

MC-50-	71 lbs.
MC-80-	74 lbs.
MC-99-	] 84 lbs.
MC-120-	

Failure to comply with above could result in severe personal injury, death or substantial property damage.

**C. MUNCHKIN CONTENDER WALL MOUNTING INSTRUCTIONS**

**⚠ WARNING**

This heater is heavy and awkward to lift. It is recommended and safer to install the heater with two people. Use caution as to not drop the heater which could cause personal injury. Verify that the heater is securely mounted before leaving the heater unsupervised.

The wall must be vertically plumb and capable of carrying the weight of the Munchkin Contender and its related components.

The building frame (studs) must be 16" on center. If not, you must use 1/2" minimum plywood 24" x 48", fastened with at least (14) #12 x 3" (3/16" x 3") round head tapping screws to the frame of the building to provide proper support for the heater. Alternate methods of mounting must not be used. (ex. toggle bolts, hollow wall anchors) or any other fastener other than #12 x 3" (3/16" x 3") round head tapping screws.

**CAUTION**

If the Munchkin Contender is not vertically plumb, improper and unsatisfactory operation may occur. This will cause excessive condensation build-up causing unnecessary maintenance and nuisance fault codes.

**D. INSTALLATION STEPS**

- 1) Prior to lifting the Munchkin Contender Heater onto the wall, use the enclosed template to level and locate the 2 primary screws (#12 x 3" [3/16" x 3"]) round head tapping screw leaving about 1/4" under the screw head to the wall surface to allow for access to the keyway slot which is located in the back of the heater panel. It is extremely important that the line on the template is level when locating the first 2 screws. Failure to do so will result in an uneven or out of level installation.
- 2) Remove the Munchkin Contender cover and locate the 2 keyway slots over the screws, then lower the heater onto the smallest part of the keyway slot.
- 3) Once the heater is mounted on the first 2 screws, finish tightening the first two screws to the back panel, then install the 6 additional screws of the same size to the back panel holes. This will provide additional strength and support to the Munchkin Contender Heater.

## PART 5: MUNCHKIN CONTENDER PIPING

### A. RELIEF VALVE

Connect discharge piping to safe disposal location, following guidelines in the WARNING below.

#### **WARNING**

To avoid water damage or scalding due to relief valve operation:

- Discharge line must be connected to relief valve outlet and run to a safe place of disposal. Terminate the discharge line in a manner that will prevent possibility of severe burns or property damage should the valve discharge.
- Discharge line must be as short as possible and be the same size as the valve discharge connection throughout its entire length.
- Discharge line must pitch downward from the valve and terminate at least 6" above the floor drain where any discharge will be clearly visible.
- The discharge line shall terminate plain, not threaded, with a material serviceable for temperatures of 375 °F or greater.
- Do not pipe the discharge to any place where freezing could occur.
- No shutoff valve shall be installed between the relief valve and heater, or in the discharge line. Do not plug or place any obstruction in the discharge line.
- Test the operation of the valve after filling and pressurizing system by lifting the lever. Make sure the valve discharges freely. If the valve fails to operate correctly, replace it with a new relief valve.
- For heaters installed with only a pressure relief valve, the separate storage vessel must have a temperature and pressure relief valve installed. This relief valve shall comply with the standard for *Relief Valves for Hot Water Supply Systems, ANSI Z21.22 CSA4.4*.
- Failure to comply with the above guidelines could result in failure of the relief valve to operate, resulting in possibility of severe personal injury, death or substantial property damage.

### B. GENERAL PIPING INFORMATION

#### **CAUTION**

Use two wrenches when tightening water piping at heater, using one wrench to prevent the heater return line or supply line from turning. Failure to support the heater piping connections to prevent them from turning could cause damage to heater components.

### **NOTICE**

The Munchkin Contender Heater control module uses temperature sensors to provide both high limit protection and modulating temperature control. The control module also provides low water protection by sensing the water pressure of the heat exchanger. Some codes/jurisdictions may require additional external controls for high limit and/or low water cutoff protection.

### C. SEPARATE LOW WATER CUTOFF

A low water cutoff may be required by state local code or some insurance companies. Check code requirements before installation of the Munchkin Contender Heater. It is also required that a low water cutoff be used if the heater is installed above the piping level.

If required:

- Use a low water cutoff designed for hydronic installations that is an electrode probe type
- Install in a tee on the supply piping above the heater
- Follow low water cutoff manufacturer's instructions

### D. BACKFLOW PREVENTER

Use a backflow preventer specifically designed for hydronic heater installations. This valve should be installed on the cold water fill supply line per local codes. (See piping details at the end of this section.)

### **CAUTION**

All piping methods shown in this manual use primary/secondary connection to the heater loop. This is to avoid the possibility of noise or actuator problems in zone valves because of the high-head heater circulator. For other piping methods, consult your local Heat Transfer Products representative or refer to separate Munchkin Contender piping details in this manual (Part 5).

### E. SYSTEM WATER PIPING METHODS

#### Expansion tank and make-up water

1. Ensure expansion tank size will handle heater and system water volume and temperature. Allow 3 gallons for the heater and its piping.

## PART 5: MUNCHKIN CONTENDER PIPING (CONTINUED)

### CAUTION

**Undersized expansion tanks cause system water to be lost from relief valve and makeup water to be added through fill valve. Eventual failure can result due to excessive make-up water addition.**

- Expansion tank must be located as shown in Piping Part 5, or following recognized design methods. See tank manufacturer's instructions for details.
- Connect the expansion tank to the air separator only if the separator is on the suction side of the circulator. Always install the system fill connection at the same point as the expansion tank connection to the system.
- Most chilled water systems are piped using a closed type expansion tank.

### Diaphragm (or bladder) expansion tank

- Always install an automatic air vent on top of the air separator to remove residual air from the system.

### F. CIRCULATORS

#### CAUTION

**DO NOT install automatic air vents on closed-type expansion tank systems. Air must remain in the system and return to the tank to provide its air cushion. An automatic air vent would cause air to leave system, resulting in water-logging the expansion tank.**

#### CAUTION

**DO NOT use the heater circulator in any location other than the ones shown in this manual. The heater circulator is selected to ensure adequate flow through the Munchkin Contender. Failure to comply could result in unreliable performance and nuisance shut downs from insufficient flow.**

### Sizing space heat system piping

- See Piping Details in this manual Part 5. In all diagrams, the space heating system is isolated from the heating loop by the

primary/secondary connection.

- Size the piping and components in the space heating system using recognized design methods.

### G. HYDRONIC PIPING WITH CIRCULATORS, ZONE VALVES AND MULTIPLE HEATERS

The Munchkin Contender is designed to function in a closed loop 15 PSI System. A factory installed water pressure switch will ensure that you have adequate pressure in the system. The Munchkin Contender will not operate without a minimum of 10 PSI water pressure. This assures you that if the system does have leak, the Munchkin Contender will lock out (PRO on the display) before it damages the Stainless Steel Heat Exchanger. We have also included a Temperature and Pressure gauge which allows the user to monitor the system pressure and outlet temperature from the Munchkin Contender. It is important to note that the Munchkin Contender has a minimal amount of pressure drop and must be calculated when sizing the circulators. Each Munchkin Contender installation must have an Air Elimination device that will remove air from the system. Install the Munchkin Contender so the gas ignition system components are protected from water (dripping, spraying, etc.) allowing clearance for basic service of circulator replacement, valves and other. Observe minimum 1" clearance around all un-insulated hot water pipes when openings around pipes are not protected by non-combustible materials. On a Munchkin Contender installed above radiation level, some states and local codes require a low water cut off device at the time of installation (See Part C this section). If the Munchkin Contender supplies hot water to heating coils in air handler units, flow control valves or other devices must be installed to prevent gravity circulation of heater water in the coils during the cooling cycle. Chilled Water Medium must be piped in parallel with the heater. Freeze Protection for new or existing systems must use glycol that is specifically formulated for this purpose. It will include inhibitors that will prevent the glycol from attacking the metallic system components. Make certain that the system fluid is checked for the correct glycol

**PART 5: MUNCHKIN CONTENDER PIPING (CONTINUED)**

concentration and inhibitor level. The system should be tested at least once a year and as recommend by the producer of the glycol solution. Allowance should be made for the expansion of the glycol solution in the system piping. Example 50% by volume solution expands 4.8% in volume for the temperature increase from 32 F to 180 F, while water expands 3% with the same temperature rise.

Basic steps are listed below, with Illustration, which will guide you through the installation of the Munchkin.

**⚠ CAUTION**

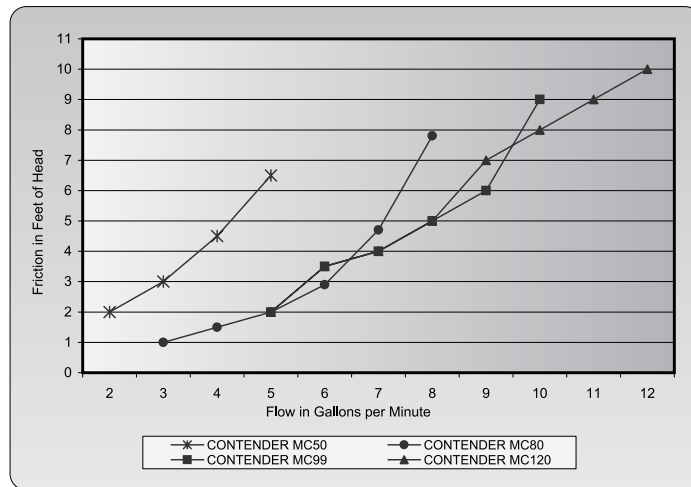
**The Munchkin Contender should not be operated as a potable Hot Water Heater.**

1. Connect the system return marked "Heater In".
2. Connect the system supply marked "Heater Out".
3. Install Purge and Balance Valve or shut off valve and drain on system return to purge air out of each zone.
4. Install a Back Flow preventor on the Cold Feed Make-Up Water line.
5. Install a Pressure Reducing Valve on the Cold Feed Make-Up Water line, (15 PSI nominal on the system return). Check Temperature and Pressure Gauge which should read minimum pressure of 12 PSI.

6. Install a circulator as shown in piping details (this section). Make sure the circulator is properly sized for the system and friction loss.
7. Install an Expansion Tank on the system supply. Consult the tank manufacturer's instruction for specific information relating to expansion tank installation. Size the expansion tank for the required system volume and capacity.
8. Install an Air Elimination Device on the system supply.
9. Install a drain valve at the lowest point of the system. Note: The Munchkin Contender can not be drained completely of water without purging the unit with an air pressure 15 PSI.
10. The Safety Relief Valve is installed at the factory. Pipe the discharge of the safety relief valve to prevent injury in the event of pressure relief. Pipe the discharge 6" above the drain to a drain. Provide piping that is the same size as the safety relief valve outlet. **Never block the outlet of safety relief valve.**

**H. CIRCULATOR SIZING**

The Munchkin Contender Heat Exchanger does have pressure drop which must be considered in your system design. Refer to the graph in Fig. 5-1 below for pressure drop through the Munchkin Contender Heat Exchanger for recommended pump selection at a 20Δt design.



HEATER	TACO P/N	GRUNDFOS P/N	BELL & GOSSET
MC50 / MC80	007 *	UPS15-58 FC SPD 2	NRF-22
MC99 / MC120	0010 *	26-64 F	NRF-22

**Figure 5-1**

\* NOTE: The recommended circulators are based on 1 gpm per 10,000 btu/hr with 20°Δt.



## PART 5: MUNCHKIN CONTENDER PIPING (CONTINUED)

The chart below represents the various system temperatures and their respective flows and friction loss through the Munchkin Contender which will aid circulator selection.

SYSTEM TEMPERATURE RISE CHART												
Model	20° Δt		25° Δt		30° Δt		35° Δt		40° Δt		45° Δt	
	Friction Feet	Flow GPM	Friction Feet	Flow GPM	Friction Feet	Flow GPM	Friction Feet	Flow GPM	Friction Feet	Flow GPM	Friction Feet	Flow GPM
MC-50	6.5'	5	4.5'	4	3'	3.3	2'	2.5	N/R	N/R	N/R	N/R
MC-80	7.8'	8	4.7'	6.4	2.9'	5.3	2'	4.6	1.5'	4	1'	3.5
MC-99	9'	10	6'	9	5'	7.8	4'	6.3	3.5'	5.6	2'	4.8
MC-120	10'	12	7'	9.6	5'	8	4'	6.8	3.5'	6	2'	5.3

N/R = Not recommended

### I. FILL AND PURGE HEATING SYSTEM

- Attach the hose to balance and purge hose connector or drain valve and run hose to nearest drain
- Close the other side of the balance and purge valve or the shut off valve after the drain.
- Open first zone balance and purge or drain valve to let water flow out the hose. If zone valves are used, open the valves one at a time manually. (Note: You should check valve manufacturer's instruction prior to opening valves manually, so as not to damage the valve.)
- Manually operate fill valve regulator. When water runs out of the hose, while it's connected to the balance and purge valve or drain you will see a steady stream of water (without bubbles). Close balance and purge valve or drain to stop the water from flowing. Disconnect the hose and connect it to next zone to be purged.
- Repeat this procedure for additional zones (one at time).

### CAUTION

For installation that incorporates standing Iron Radiation and systems with manual vents at the high points. Follow above section and starting with the nearest manual air vent, open vent until water flows out, then close vent. Repeat procedure, working your way toward furthest air vent. It may be necessary to install a basket strainer in an older system where larger amounts of sediment may be present. Annual cleaning of the strainer may be necessary.

Upon completion, make sure that the fill valve is in automatic position and each zone balance and purge or shut off is in an open position and zone valves are positioned for automatic operation.

### WARNING

Use only inhibited propylene glycol solutions which are specially formulated for hydronic systems. Ethylene glycol is toxic and can attack gaskets and seals used in hydronic systems. Glycol mixtures should not exceed 50%.

1. Glycol in hydronic applications which is specially formulated for this purpose includes inhibitors that prevent the glycol from attacking metallic system components. Make certain that the system fluid is checked for the correct glycol concentration and inhibitor level.
2. The glycol solution should be tested at least once a year and as recommended by the glycol manufacturer.
3. Anti-freeze solutions expand more than water. For example a 50% by volume solution expands 4.8% in volume for a temperature increase from 32° F to 180° F, while water expands 3% with the same temperature rise. Allowances must be made for this expansion in the system design.
4. A 30% mixture of glycol will result in a BTU output loss of 15% with a 5% increase in head against system circulator.
5. A 50% mixture of glycol will result in a BTU output loss of 30% with a 50% increase in head against system circulator.

## MUNCHKIN CONTENDER PIPING (CONTINUED)

### CAUTION

It is highly recommended that you carefully follow the glycol manufacturer's recommended concentrations, expansion requirements and maintenance recommendations (pH additive breakdown, inhibitor reduction, etc.). You must carefully figure the additional friction loss in the system as well as the reduction in heat transfer co-efficients.

### J. ZONING WITH ZONE VALVES

1. Connect heater to system as shown in 1A and 1B in Piping Details when zoning with zone valves. The primary/secondary piping shown ensures the heater loop will have sufficient flow. It also avoids applying the high head of the heater circulator to the zone valves.
2. Connect DHW (domestic hot water) piping to indirect storage water heater as shown.

### K. ZONING WITH CIRCULATORS

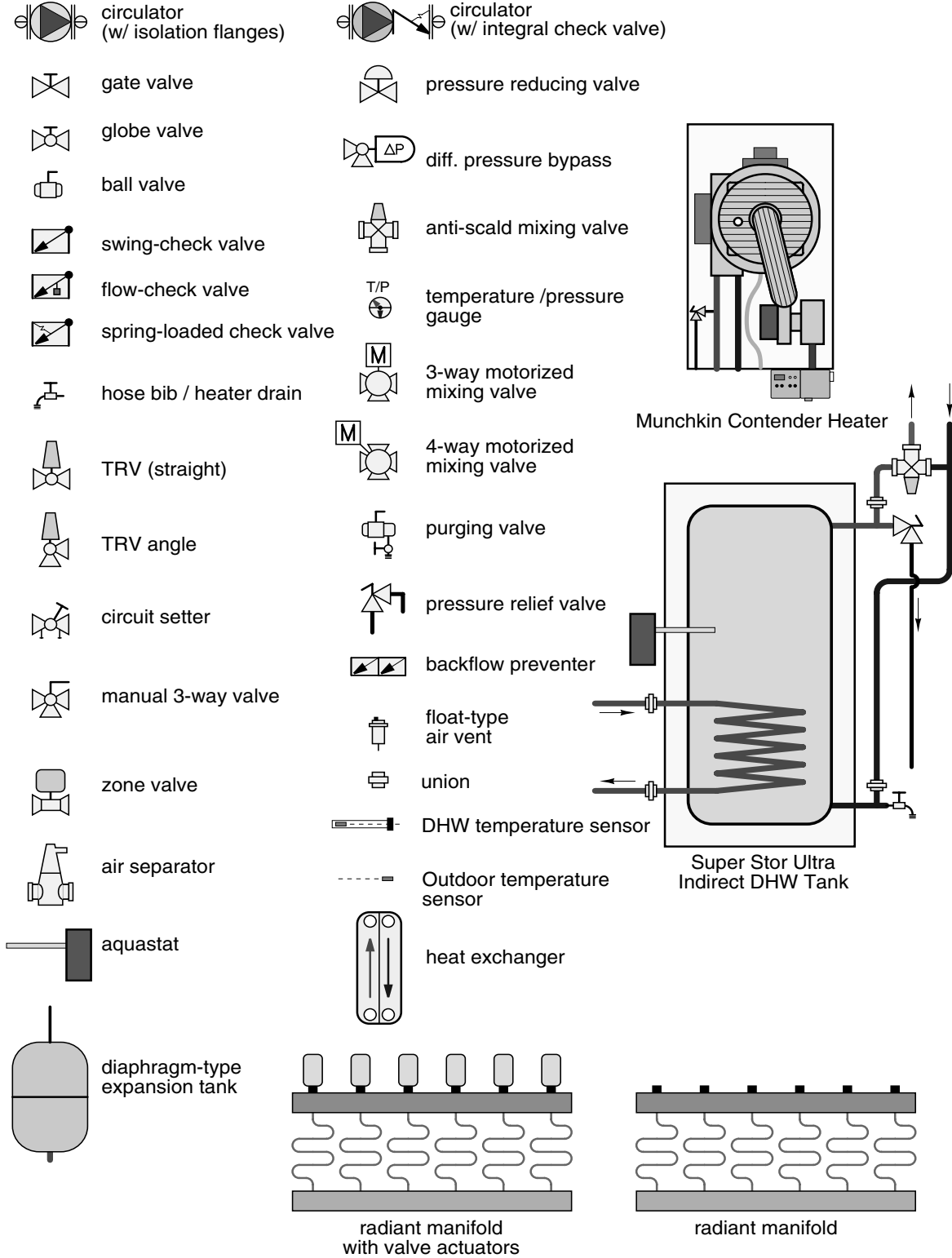
1. Connect heater to system when circulator zoning as shown in 1C and 1D in Piping Details when zoning with circulators. The heater circulator cannot be used for a zone. It must supply only the heater loop.
2. Install a separate circulator for each zone.
3. Connect DHW (domestic hot water) piping to indirect storage water heater as shown.

### L. MULTIPLE HEATERS

1. Connect multiple heaters as shown in 1E and 1F in Piping Details.
2. All piping shown is reverse return to assure balanced flow through the connected heaters.
3. Each connected heater must have its own circulator pump to assure adequate flow.
4. Connect DHW (domestic hot water) piping to indirect storage water heater as shown.

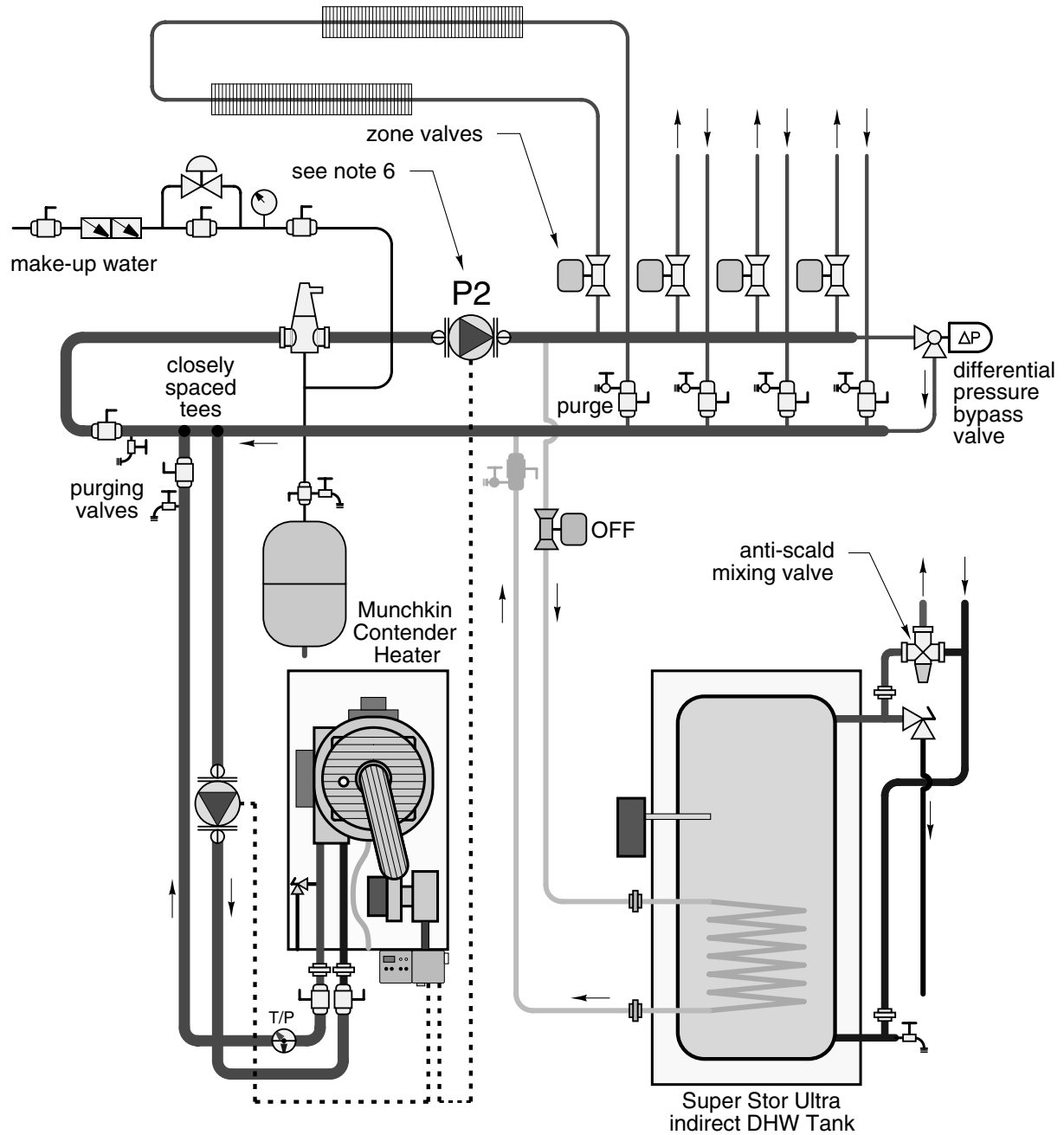
M. CONTENDER PIPING DETAILS

# Piping symbol legend



Standard Munchkin Contender Heater  
(zoning with valves)  
Space heating mode

Drawing 1A

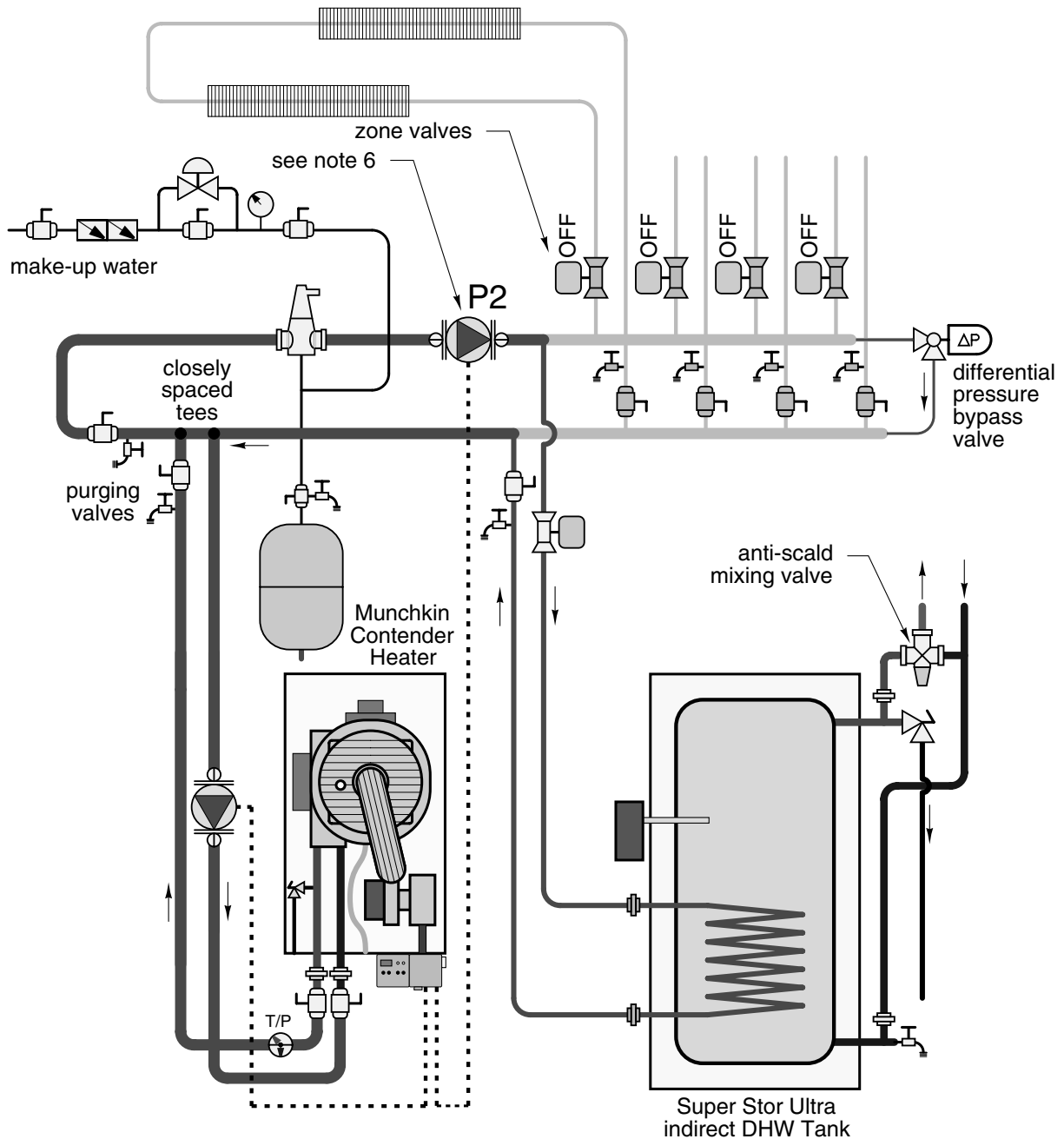


NOTES:

1. This drawing is meant to show system piping concept only. Installer is responsible for all equipment & detailing required by local codes.
2. All closely spaced tees shall be within 4 pipe diameters center to center spacing.
3. A minimum of 6 pipe diameters of straight pipe shall be installed upstream & downstream of all closely spaced tees.
4. The **minimum** pipe size for connecting a Super Stor Ultra Indirect Water Heater is 1-inch.
5. The **minimum** pipe size for connecting the Munchkin Contender is 1.25-inch
6. Circulators are shown with isolation flanges. The alternative is standard flanges with full port ball valves. Purge valves can be used with the circulator flanges as an alternative.
7. The anti-scald mixing valve is recommended if the DHW temperature is set above the factory setting of 119°F.
8. Install a minimum of 12 diameters of straight pipe upstream of all circulators.
9. **Winterization:** When winterizing the Munchkin Contender, put a drain valve on both the supply and return between the union and the shut-off connection.

Standard Munchkin Contender Heater  
(zoning with valves)  
Domestic water heating mode

Drawing 1B

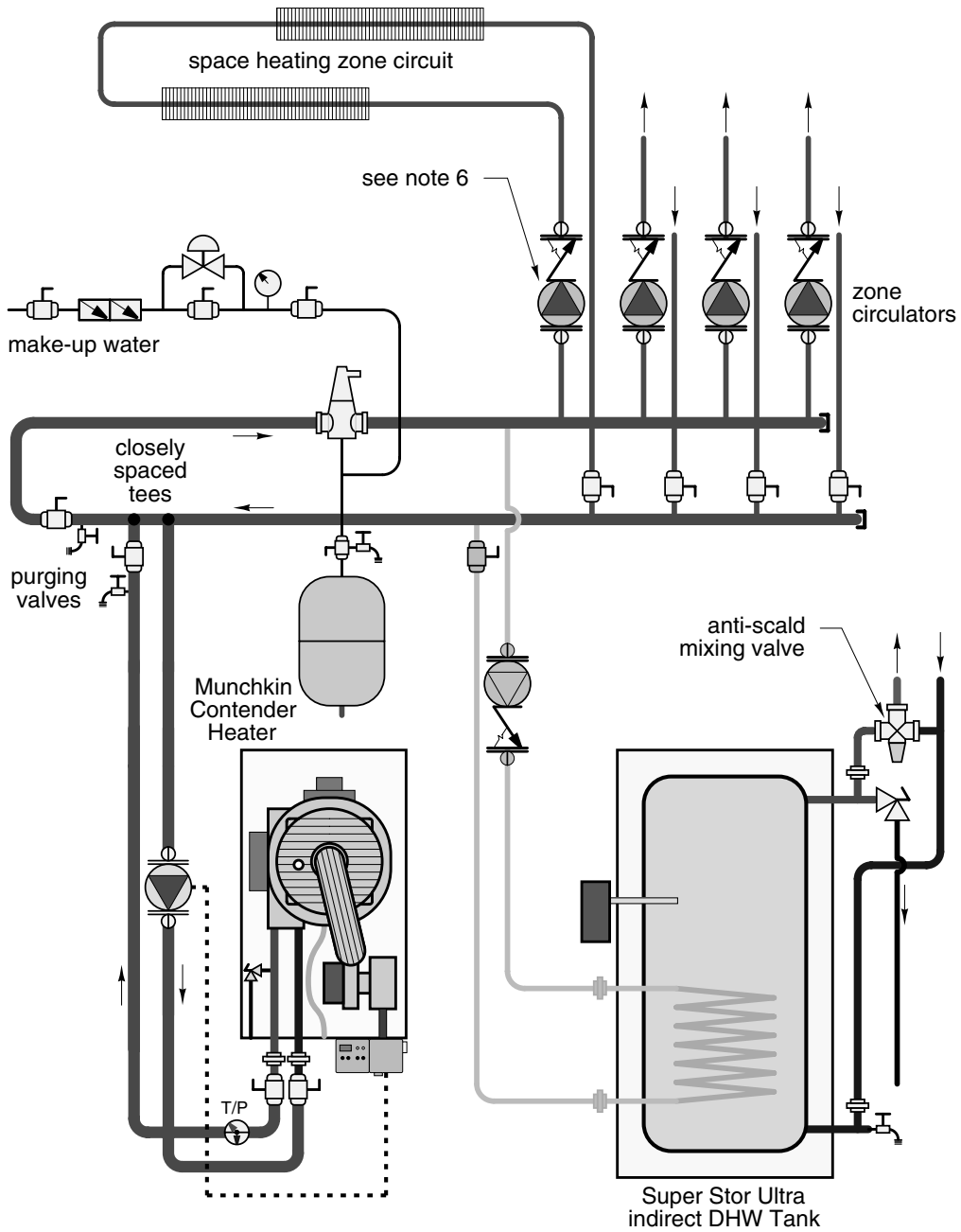


NOTES:

1. This drawing is meant to show system piping concept only. Installer is responsible for all equipment & detailing required by local codes.
2. All closely spaced tees shall be within 4 pipe diameters center to center spacing.
3. A minimum of 6 pipe diameters of straight pipe shall be installed upstream & downstream of all closely spaced tees.
4. The **minimum** pipe size for connecting a Super Stor Ultra Indirect Water Heater is 1-inch.
5. The **minimum** pipe size for connecting the Munchkin Contender is 1.25-inch.
6. Circulators are shown with isolation flanges. The alternative is standard flanges with full port ball valves. Purge valves can be used with the circulator flanges as an alternative.
7. The anti-scald mixing valve is recommended if the DHW temperature is set above the factory setting of 119°F.
8. Install a minimum of 12 diameters of straight pipe upstream of all circulators.
9. **Winterization:** When winterizing the Munchkin Contender, put a drain valve on both the supply and return between the union and the shut-off connection.

Standard Munchkin Contender Heater  
Preferred piping (zoning with circulators)  
Space heating mode

Drawing 1C

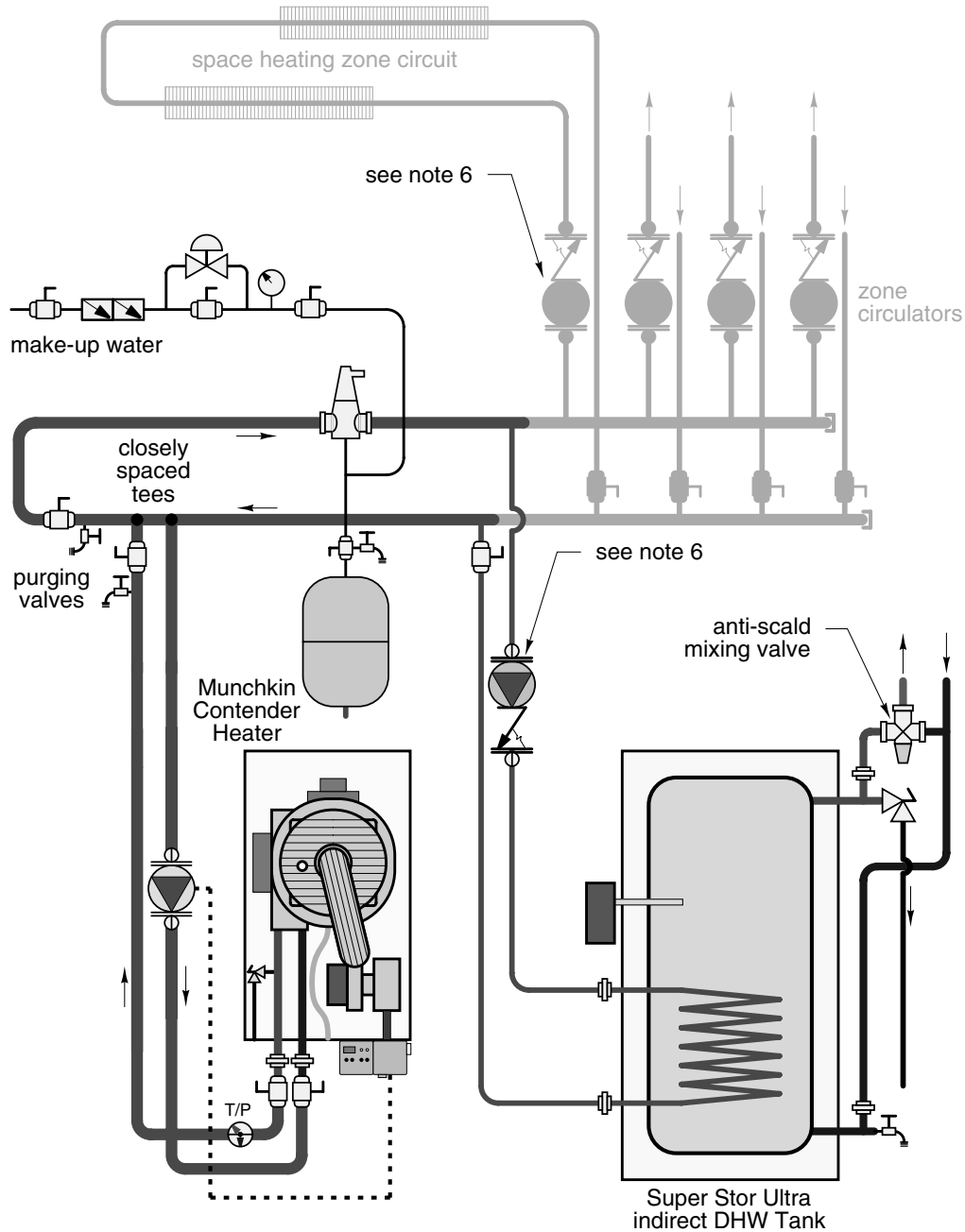


NOTES:

1. This drawing is meant to show system piping concept only. Installer is responsible for all equipment & detailing required by local codes.
2. All closely spaced tees shall be within 4 pipe diameters center to center spacing.
3. A minimum of 6 pipe diameters of straight pipe shall be installed upstream & downstream of all closely spaced tees.
4. The **minimum** pipe size for connecting a Super Stor Ultra Indirect Water Heater is 1-inch.
5. The **minimum** pipe size for connecting the Munchkin Contender is 1.25-inch
6. Circulators are shown with isolation flanges and integral check valves. The alternative is standard flanges with full port ball valves and a separate flow check valve. Purge valves can be used with the circulator flanges as an alternative.
7. The anti-scald mixing valve is recommended if the DHW temperature is set above the factory setting of 119°F.
8. Install a minimum of 12 diameters of straight pipe upstream of all circulators.
9. **Winterization:** When winterizing the Munchkin Contender, put a drain valve on both the supply and return between the union and the shut-off connection.

Standard Munchkin Contender Heater  
(zoning with circulators)  
Domestic water heating mode

Drawing 1D

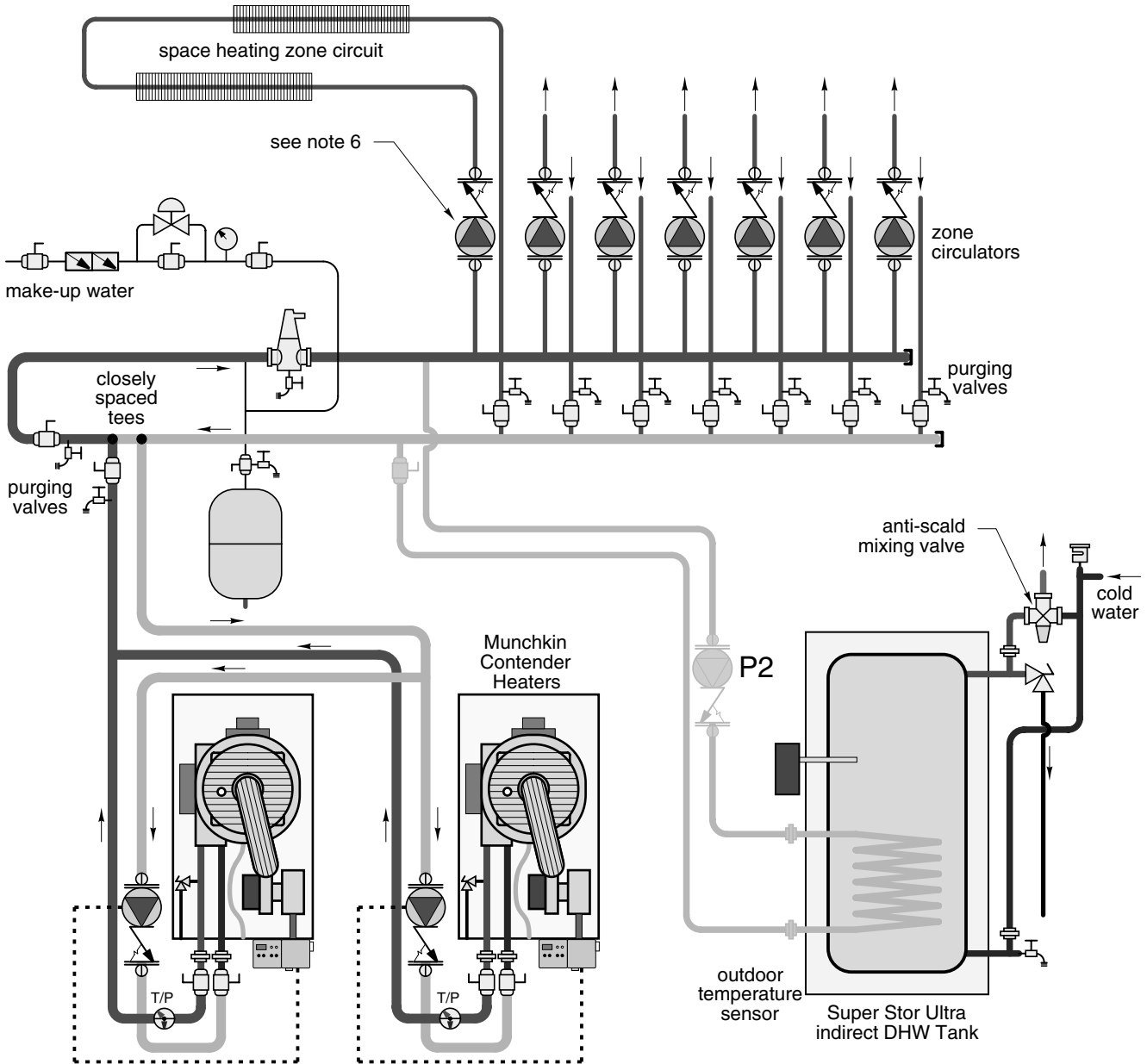


NOTES:

1. This drawing is meant to show system piping concept only. Installer is responsible for all equipment & detailing required by local codes.
2. All closely spaced tees shall be within 4 pipe diameters center to center spacing.
3. A minimum of 6 pipe diameters of straight pipe shall be installed upstream & downstream of all closely spaced tees.
4. The **minimum** pipe size for connecting a Super Stor Ultra Indirect Water Heater is 1-inch.
5. The **minimum** pipe size for connecting the Munchkin Contender is 1.25-inch.
6. Circulators are shown with isolation flanges and integral check valves. The alternative is standard flanges with full port ball valves and a separate flow check valve. Purge valves can be used with the circulator flanges as an alternative.
7. The anti-scald mixing valve is recommended if the DHW temperature is set above the factory setting of 119°F.
8. Install a minimum of 12 diameters of straight pipe upstream of all circulators.
8. **Winterization:** When winterizing the Munchkin Contender, put a drain valve on both the supply and return between the union and the shut-off connection.

Multiple Munchkin Contender Heaters  
 Preferred piping  
 (zoning with circulators)  
 Space heating mode

Drawing 1E



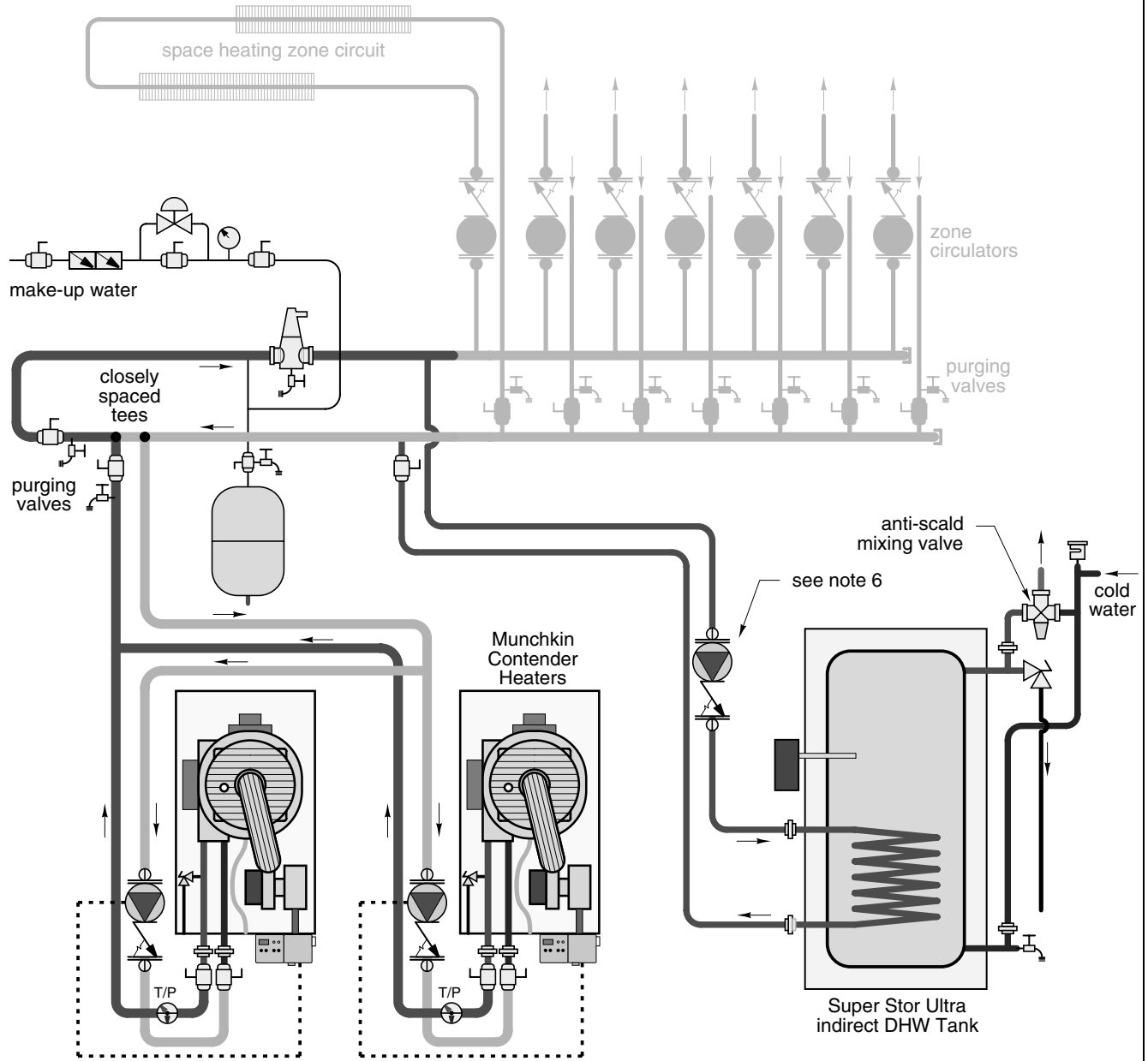
NOTES:

1. This drawing is meant to show system piping concept only. Installer is responsible for all equipment & detailing required by local codes.
2. All closely spaced tees shall be within 4 pipe diameters center to center spacing.
3. A minimum of 6 pipe diameters of straight pipe shall be installed upstream & downstream of all closely spaced tees.
4. The **minimum** pipe size for connecting a Super Stor Ultra Indirect Water Heater is 1-inch.
5. The **minimum** pipe size for connecting the Munchkin Contender is 1.25-inch
6. Circulators are shown with isolation flanges and integral check valves. The alternative is standard flanges with full port ball valves and a separate flow check valve. Purge valves can be used with the circulator flanges as an alternative.
7. The anti-scald mixing valve is recommended if the DHW temperature is set above the factory setting of 119°F.
8. Install a minimum of 12 diameters of straight pipe upstream of all circulators.
9. **Winterization:** When winterizing the Munchkin Contender, put a drain valve on both the supply and return between the union and the shut-off connection.



Multiple Munchkin Contender Heaters  
Preferred piping  
(zoning with circulators)  
Domestic water heating mode

Drawing 1F



NOTES:

1. This drawing is meant to show system piping concept only. Installer is responsible for all equipment & detailing required by local codes.
2. All closely spaced tees shall be within 4 pipe diameters center to center spacing.
3. A minimum of 6 pipe diameters of straight pipe shall be installed upstream & downstream of all closely spaced tees.
4. The minimum pipe size for connecting a Super Stor Ultra Indirect Water Heater is 1-inch.
5. The minimum pipe size for connecting the Munchkin Contender is 1.25-inch
6. Circulators are shown with isolation flanges and integral check valves. The alternative is standard flanges with full port ball valves and a separate flow check valve. Purge valves can be used with the circulator flanges as an alternative.
7. The anti-scald mixing valve is recommended if the DHW temperature is set above the factory setting of 119°F.
8. Install a minimum of 12 diameters of straight pipe upstream of all circulators.
9. **Winterization:** When winterizing the Munchkin Contender, put a drain valve on both the supply and return between the union and the shut-off connection.

**PART 6. MUNCHKIN CONTENDER PIPING WITH OPTIONAL VISION I SYSTEM** (DHW PRIORITY WITH OUTDOOR RESET)**A. VISION I SYSTEM PIPING**

It is important that the system piping is done correctly when using the Vision 1 System. Follow the piping diagrams 2A through 3G when piping your Munchkin Contender with Vision I. All general piping practices should still be maintained.

**B. ZONING WITH ZONE VALVES USING VISION I**

1. Connect the heater to the system as shown in piping details 2A through 2C.

2. Connect the DHW circulator (P2) directly to the heater as shown in the piping details. The heater circulator (P1) will shut down when there is a DHW demand.

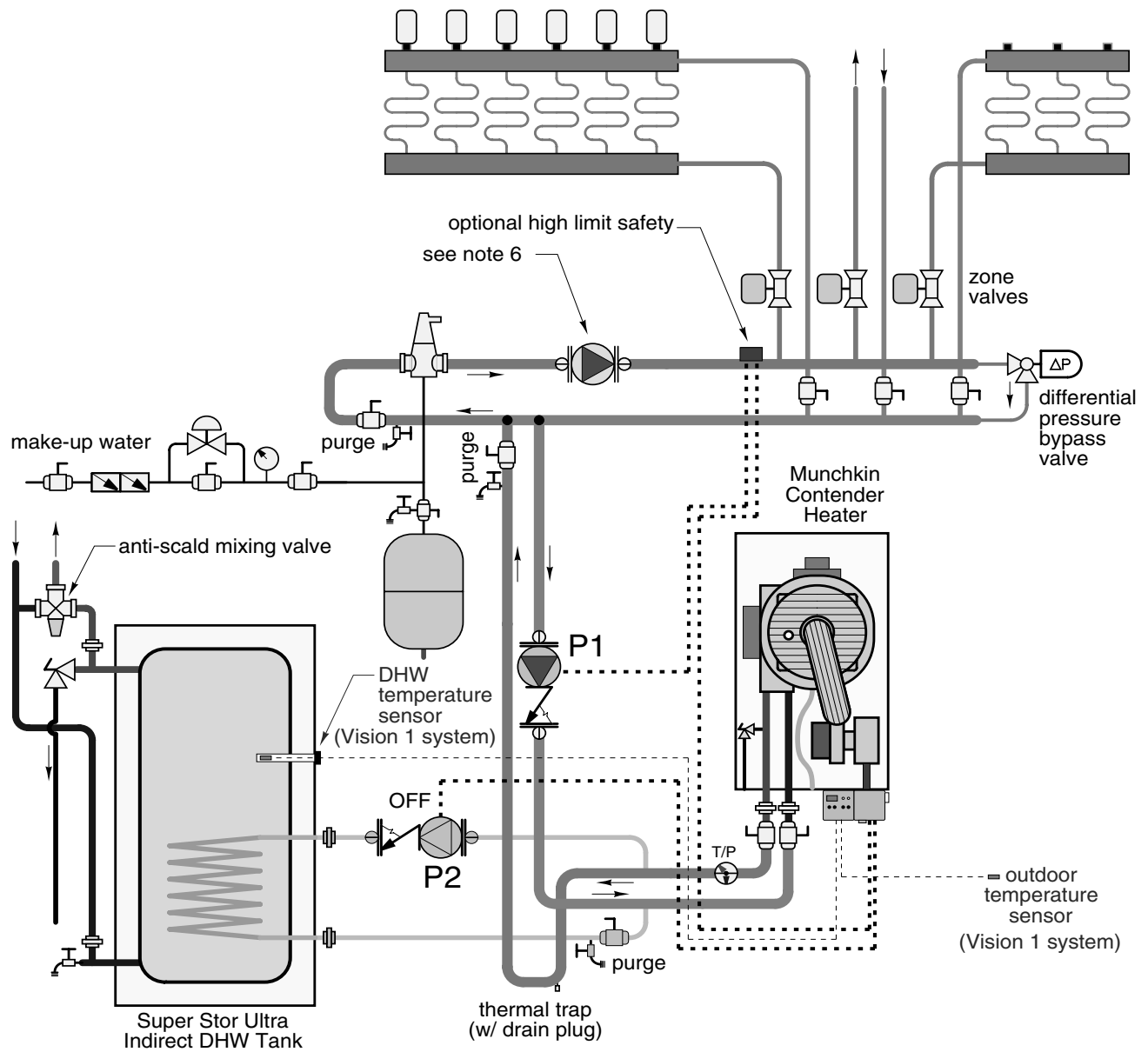
**C. ZONING WITH CIRCULATORS USING VISION I**

1. Connect the heater to the system as shown in piping details 3A through 3G.
2. Connect the DHW circulator (P2) directly to the heater as shown in the piping details. The heater circulator (P1) will shut down when there is a DHW demand.

D. HEATER PIPING DETAILS WITH THE VISION I SYSTEM

Munchkin Contender Heater with optional VISION 1 system  
(zoning with valves)  
Space heating mode

Drawing 2A

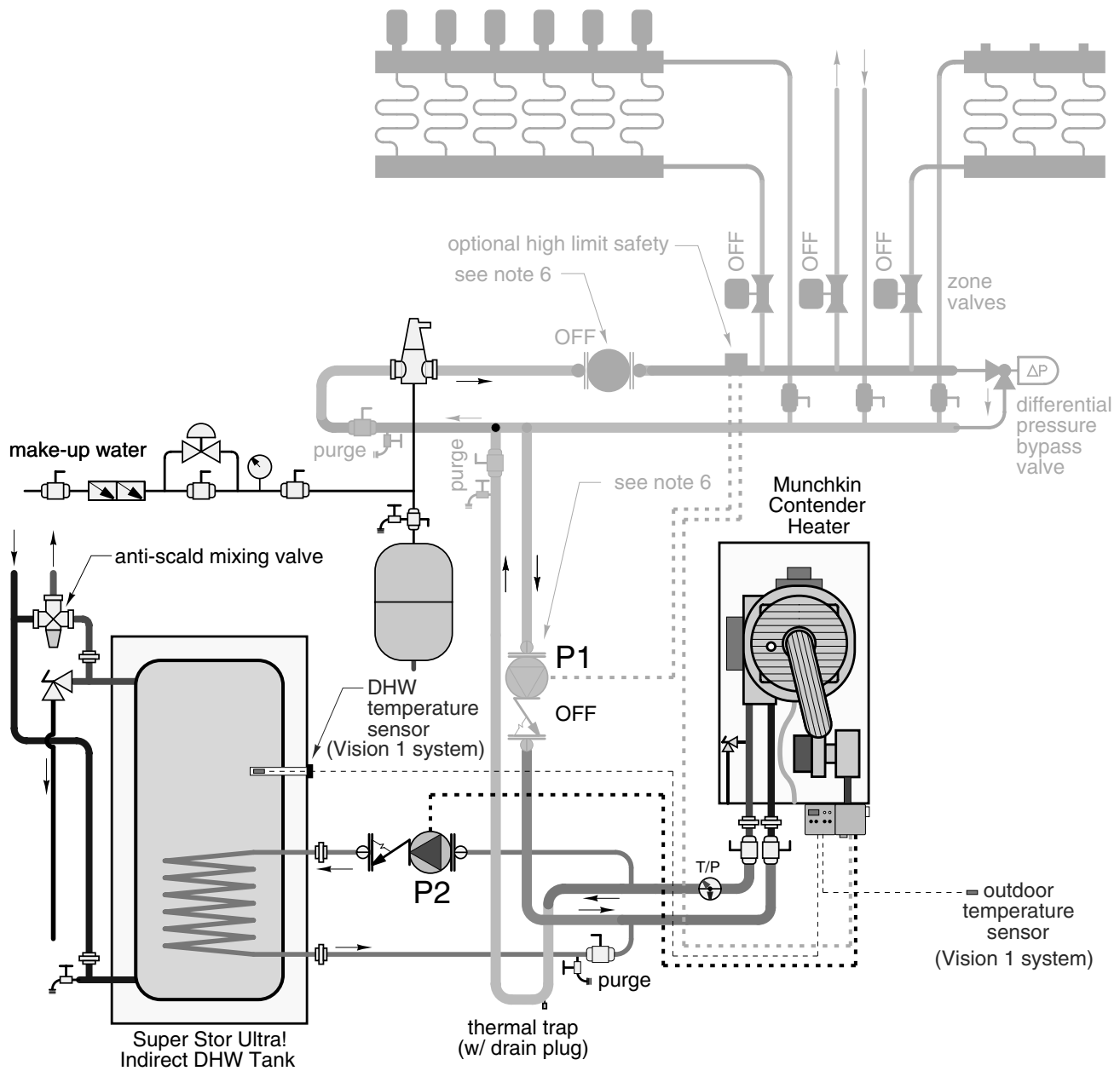


NOTES:

1. This drawing is meant to show system piping concept only. Installer is responsible for all equipment & detailing required by local codes.
2. All closely spaced tees shall be within 4 pipe diameters center to center spacing.
3. A minimum of 6 pipe diameters of straight pipe shall be installed upstream & downstream of all closely spaced tees.
4. The **minimum** pipe size for connecting a Super Stor Ultra Indirect Water Heater is 1-inch.
5. The **minimum** pipe size for connecting the Munchkin Contender is 1.25-inch
6. Circulators are shown with isolation flanges. The alternative is standard flanges with full port ball valves. Purge valves can be used with the circulator flanges as an alternative.
7. Optional Vision 1 system includes temperature sensors for DHW and outdoor air and must be purchased separately.
8. The anti-scald mixing valve is recommended if the DHW temperature is set above the factory setting of 119°F.
9. Install a minimum of 12 diameters of straight pipe upstream of all circulators.
9. **Winterization:** When winterizing the Munchkin Contender, put a drain valve on both the supply and return between the union and the shut-off connection.

Munchkin Contender Heater with optional VISION 1 system  
(zoning with valves)  
Domestic water heating mode

Drawing 2B

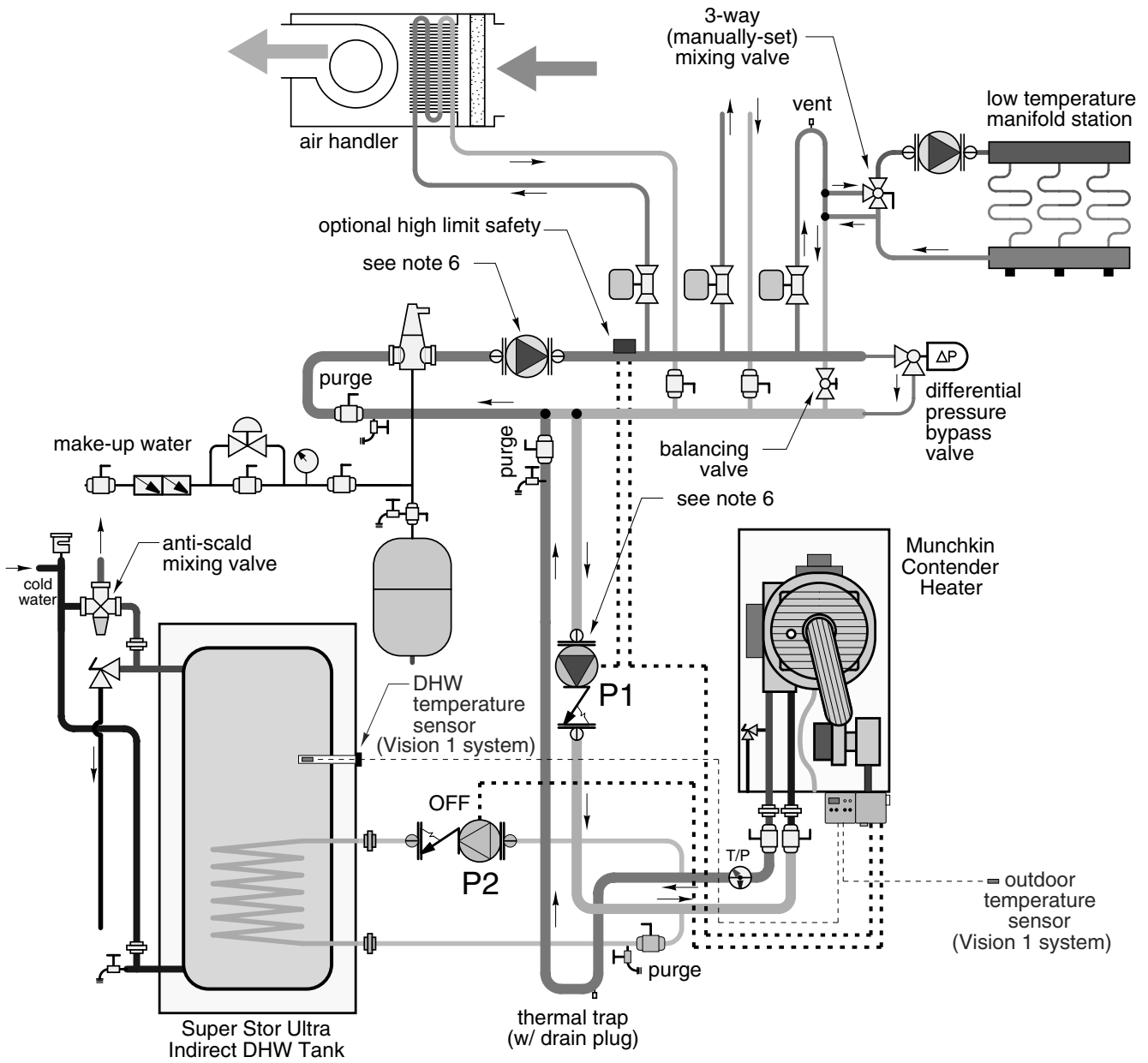


NOTES:

1. This drawing is meant to show system piping concept only. Installer is responsible for all equipment & detailing required by local codes.
2. All closely spaced tees shall be within 4 pipe diameters center to center spacing.
3. A minimum of 6 pipe diameters of straight pipe shall be installed upstream & downstream of all closely spaced tees.
4. The **minimum** pipe size for connecting a Super Stor Ultra Indirect Water Heater is 1-inch.
5. The **minimum** pipe size for connecting the Munchkin Contender is 1.25-inch
6. Circulators are shown with isolation flanges. The alternative is standard flanges with full port ball valves. Purge valves can be used with the circulator flanges as an alternative.
7. Optional Vision 1 system includes temperature sensors for DHW and outdoor air and must be purchased separately.
8. The anti-scald mixing valve is recommended if the DHW temperature is set above the factory setting of 119°F.
9. Install a minimum of 12 diameters of straight pipe upstream of all circulators.
10. **Winterization:** When winterizing the Munchkin Contender, put a drain valve on both the supply and return between the union and the shut-off connection.

Munchkin Contender Heater with optional VISION 1 system  
(zoning with valves)  
Space heating mode (w/ submixing)

Drawing 2C

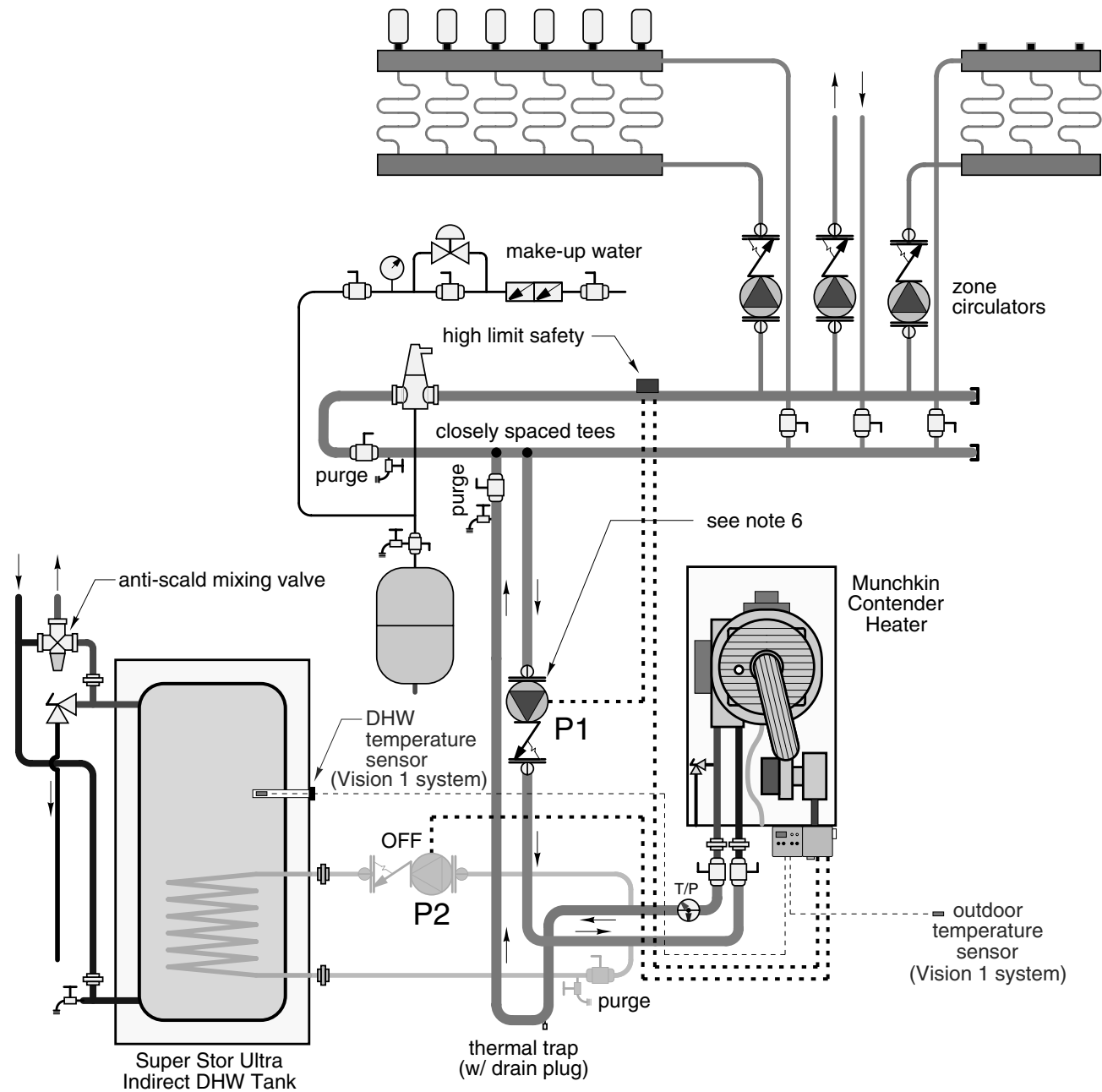


NOTES:

1. This drawing is meant to show system piping concept only. Installer is responsible for all equipment & detailing required by local codes.
2. All closely spaced tees shall be within 4 pipe diameters center to center spacing.
3. A minimum of 6 pipe diameters of straight pipe shall be installed upstream & downstream of all closely spaced tees.
4. The **minimum** pipe size for connecting a Super Stor Ultra Indirect Water Heater is 1-inch.
5. The **minimum** pipe size for connecting the Munchkin Contender is 1.25-inch
6. Circulators are shown with isolation flanges. The alternative is standard flanges with full port ball valves. Purge valves can be used with the circulator flanges as an alternative.
7. Optional Vision 1 system includes temperature sensors for DHW and outdoor air and must be purchased separately.
8. The anti-scald mixing valve is recommended if the DHW temperature is set above the factory setting of 119°F.
9. Install a minimum of 12 diameters of straight pipe upstream of all circulators.
10. **Winterization:** When winterizing the Munchkin Contender, put a drain valve on both the supply and return between the union and the shut-off connection.

Munchkin Contender Heater with optional VISION 1 system  
(zoning with circulators)  
Space heating mode

Drawing 3A

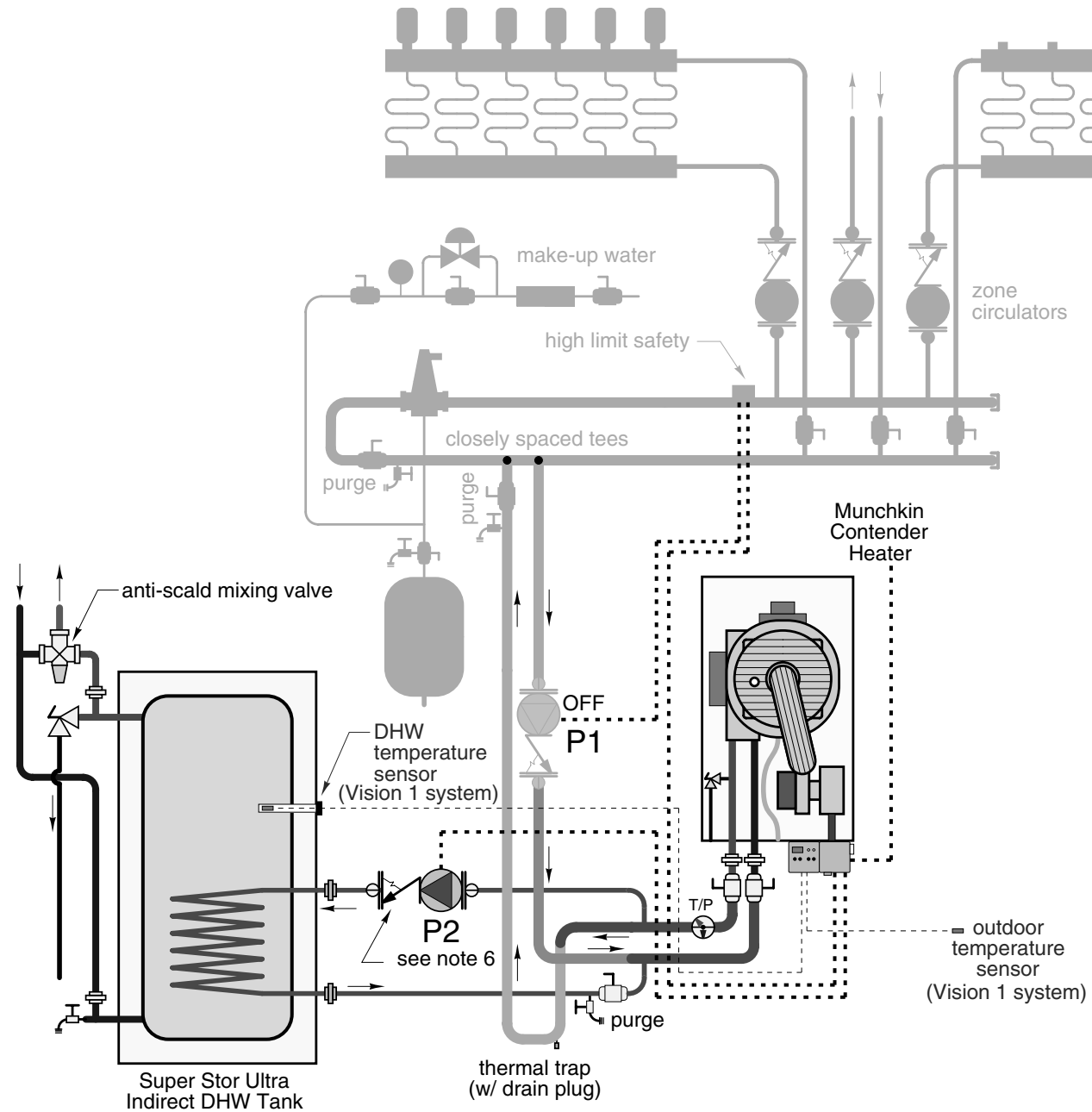


NOTES:

1. This drawing is meant to show system piping concept only. Installer is responsible for all equipment & detailing required by local codes.
2. All closely spaced tees shall be within 4 pipe diameters center to center spacing.
3. A minimum of 6 pipe diameters of straight pipe shall be installed upstream & downstream of all closely spaced tees.
4. The **minimum** pipe size for connecting a Super Stor Ultra Indirect Water Heater is 1-inch.
5. The **minimum** pipe size for connecting the Munchkin Contender is 1.25-inch
6. Circulators are shown with isolation flanges and integral check valves. The alternative is standard flanges with full port ball valves and a separate flow check valve. Purge valves can be used with the circulator flanges as an alternative.
7. Optional Vision 1 system includes temperature sensors for DHW and outdoor air and must be purchased separately.
8. The anti-scald mixing valve is recommended if the DHW temperature is set above the factory setting of 119°F.
9. Install a minimum of 12 diameters of straight pipe upstream of all circulators.
10. **Winterization:** When winterizing the Munchkin Contender, put a drain valve on both the supply and return between the union and the shut-off connection.

Munchkin Contender Heater with optional VISION 1 system  
(zoning with circulators)  
Domestic water heating mode

Drawing 3B

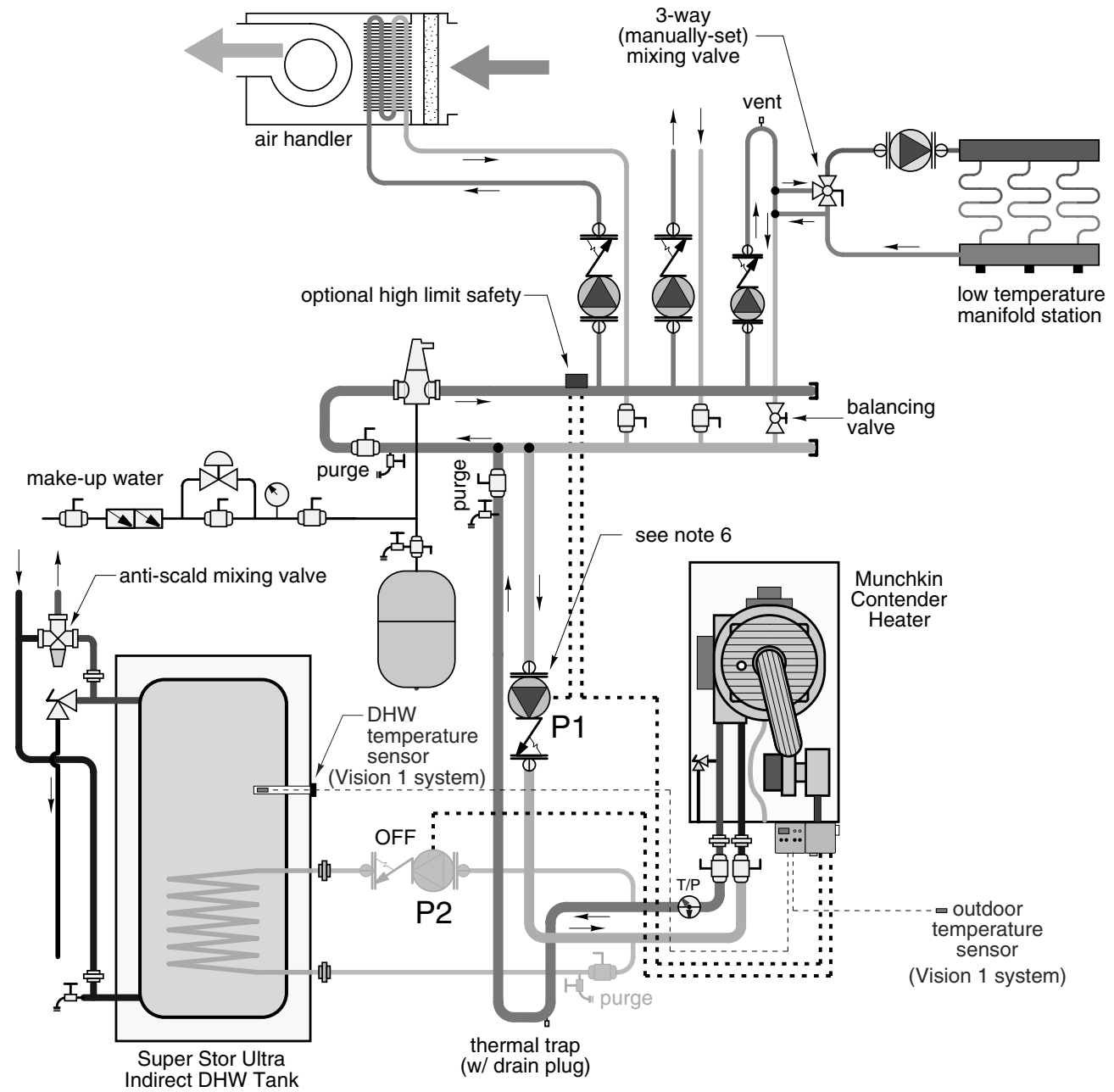


NOTES:

1. This drawing is meant to show system piping concept only. Installer is responsible for all equipment & detailing required by local codes.
2. All closely spaced tees shall be within 4 pipe diameters center to center spacing.
3. A minimum of 6 pipe diameters of straight pipe shall be installed upstream & downstream of all closely spaced tees.
4. The **minimum** pipe size for connecting a Super Stor Ultra Indirect Water Heater is 1-inch.
5. The **minimum** pipe size for connecting the Munchkin Contender is 1.25-inch.
6. Circulators are shown with isolation flanges and integral check valves. The alternative is standard flanges with full port ball valves and a separate flow check valve. Purge valves can be used with the circulator flanges as an alternative.
7. Optional Vision 1 system includes temperature sensors for DHW and outdoor air and must be purchased separately.
8. The anti-scald mixing valve is recommended if the DHW temperature is set above the factory setting of 119°F.
9. Install a minimum of 12 diameters of straight pipe upstream of all circulators.
10. **Winterization:** When winterizing the Munchkin Contender, put a drain valve on both the supply and return between the union and the shut-off connection.

Munchkin Contender Heater with optional VISION 1 system  
(zoning with circulators)  
Space heating mode (w/ submixing)

Drawing 3C



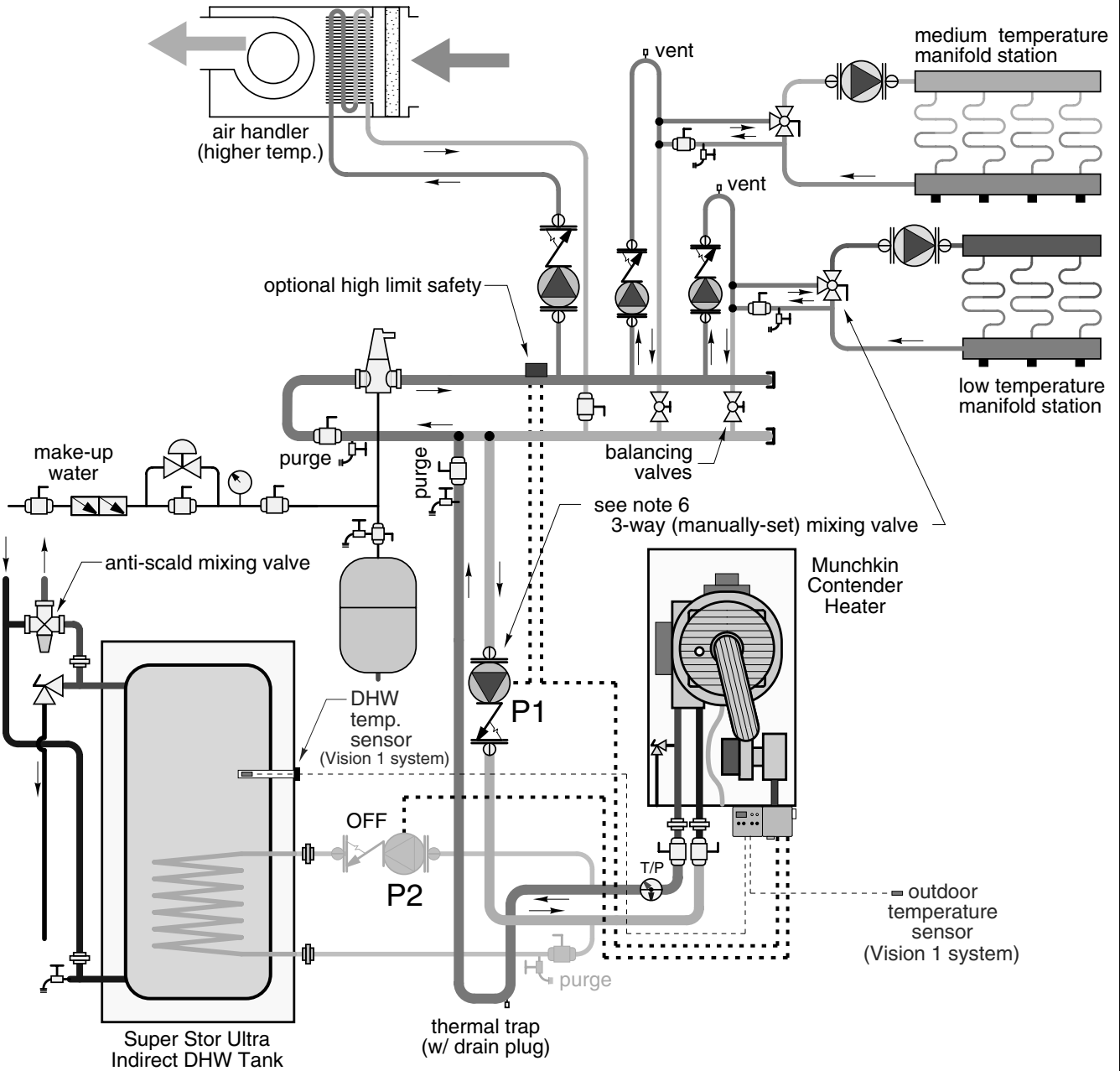
NOTES:

1. This drawing is meant to show system piping concept only. Installer is responsible for all equipment & detailing required by local codes.
2. All closely spaced tees shall be within 4 pipe diameters center to center spacing.
3. A minimum of 6 pipe diameters of straight pipe shall be installed upstream & downstream of all closely spaced tees.
4. The **minimum** pipe size for connecting a Super Stor Ultra Indirect Water Heater is 1-inch.
5. The **minimum** pipe size for connecting the Munchkin Contender is 1.25-inch.
6. Circulators are shown with isolation flanges and integral check valves. The alternative is standard flanges with full port ball valves and a separate flow check valve. Purge valves can be used with the circulator flanges as an alternative.
7. Optional Vision 1 system includes temperature sensors for DHW and outdoor air and must be purchased separately.
8. The anti-scald mixing valve is recommended if the DHW temperature is set above the factory setting of 119°F.
9. Install a minimum of 12 diameters of straight pipe upstream of all circulators.
10. **Winterization:** When winterizing the Munchkin Contender, put a drain valve on both the supply and return between the union and the shut-off connection.



Munchkin Contender Heater with optional VISION 1 system  
 (zoning with circulators)  
 Space heating mode (3 fully reset supply temperatures)

Drawing 3D

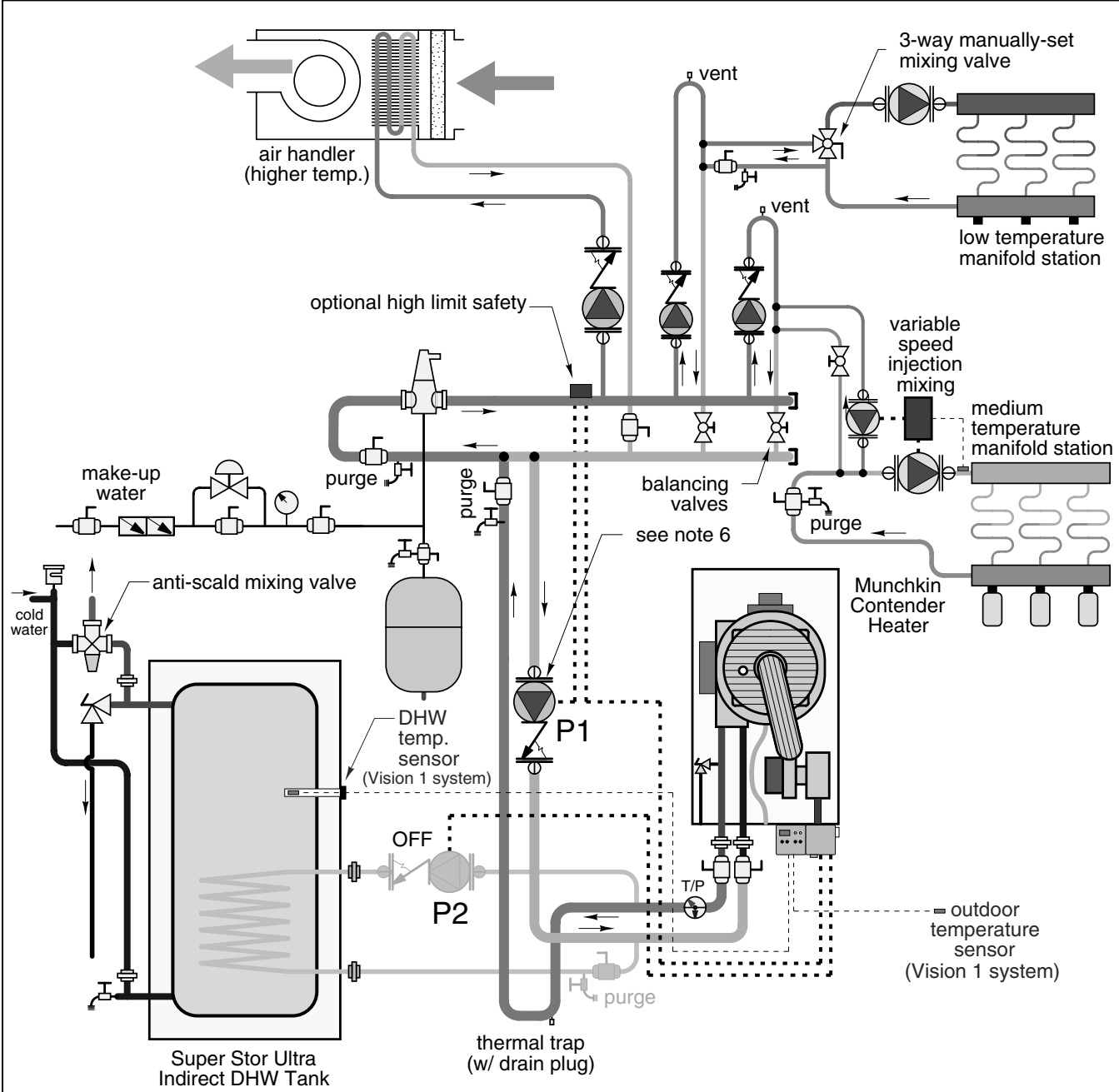


NOTES:

1. This drawing is meant to show system piping concept only. Installer is responsible for all equipment & detailing required by local codes.
2. All closely spaced tees shall be within 4 pipe diameters center to center spacing.
3. A minimum of 6 pipe diameters of straight pipe shall be installed upstream & downstream of all closely spaced tees.
4. The **minimum** pipe size for connecting a Super Stor Ultra Indirect Water Heater is 1-inch.
5. The **minimum** pipe size for connecting the Munchkin Contender is 1.25-inch
6. Circulators are shown with isolation flanges and integral check valves. The alternative is standard flanges with full port ball valves and a separate flow check valve. Purge valves can be used with the circulator flanges as an alternative.
7. Optional Vision 1 system includes temperature sensors for DHW and outdoor air and must be purchased separately.
8. The anti-scald mixing valve is recommended if the DHW temperature is set above the factory setting of 119°F.
9. Install a minimum of 12 diameters of straight pipe upstream of all circulators.
10. **Winterization:** When winterizing the Munchkin Contender, put a drain valve on both the supply and return between the union and the shut-off connection.

Munchkin Contender Heater with optional VISION 1 system  
(zoning with circulators)  
Space heating mode (3 different supply temperatures)

Drawing 3E



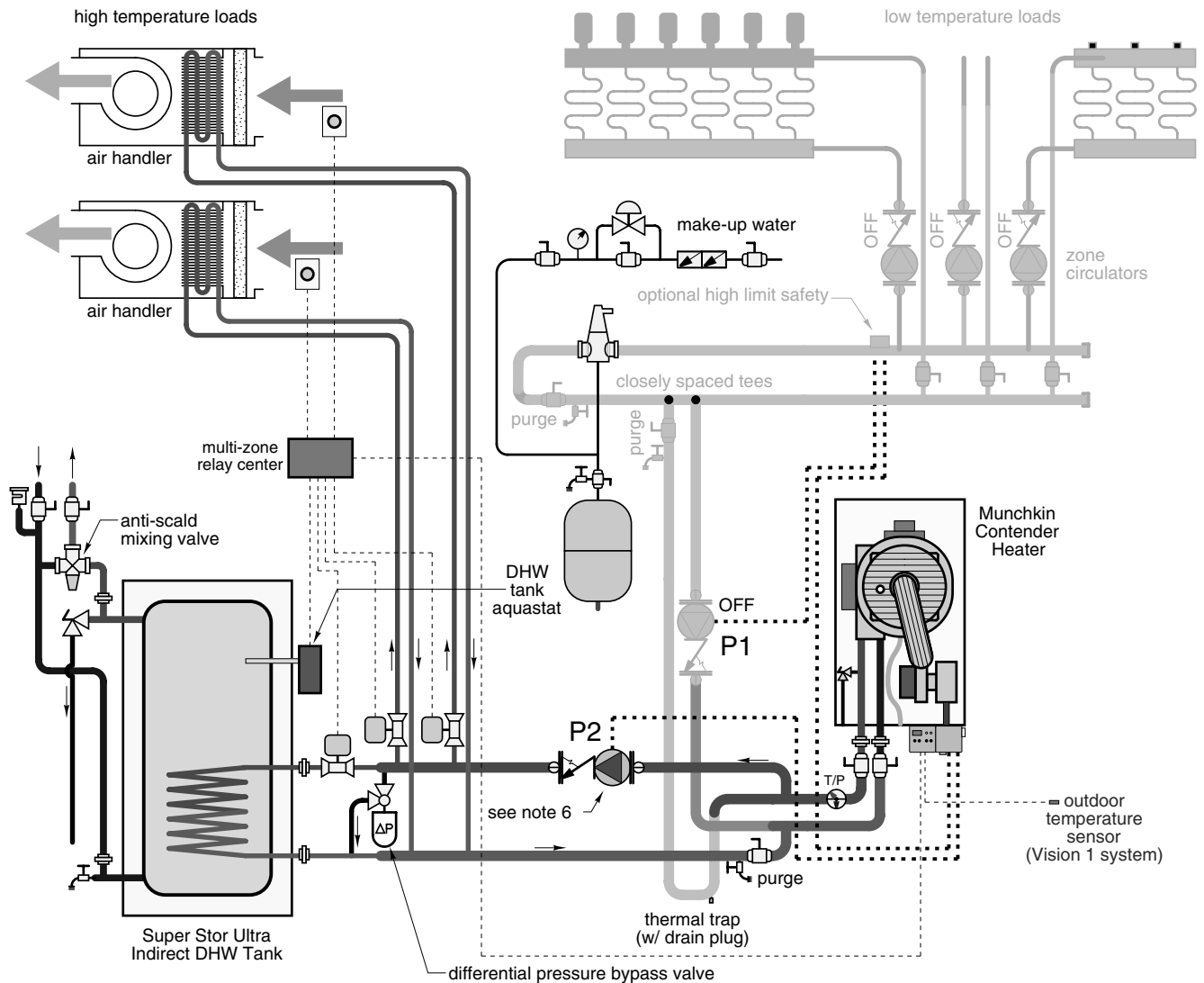
NOTES:

1. This drawing is meant to show system piping concept only. Installer is responsible for all equipment & detailing required by local codes.
2. All closely spaced tees shall be within 4 pipe diameters center to center spacing.
3. A minimum of 6 pipe diameters of straight pipe shall be installed upstream & downstream of all closely spaced tees.
4. The **minimum** pipe size for connecting a Super Stor Ultra Indirect Water Heater is 1-inch.
5. The **minimum** pipe size for connecting the Munchkin Contender is 1.25-inch
6. Circulators are shown with isolation flanges and integral check valves. The alternative is standard flanges with full port ball valves and a separate flow check valve. Purge valves can be used with the circulator flanges as an alternative.
7. Optional Vision 1 system includes temperature sensors for DHW and outdoor air and must be purchased separately.
8. The anti-scald mixing valve is recommended if the DHW temperature is set above the factory setting of 119°F.
9. Install a minimum of 12 diameters of straight pipe upstream of all circulators.
10. **Winterization:** When winterizing the Munchkin Contender, put a drain valve on both the supply and return between the union and the shut-off connection.

Munchkin Contender Heater with optional VISION 1 system

Drawing 3F

Multiple high temperature priority loads controlled with zone valves

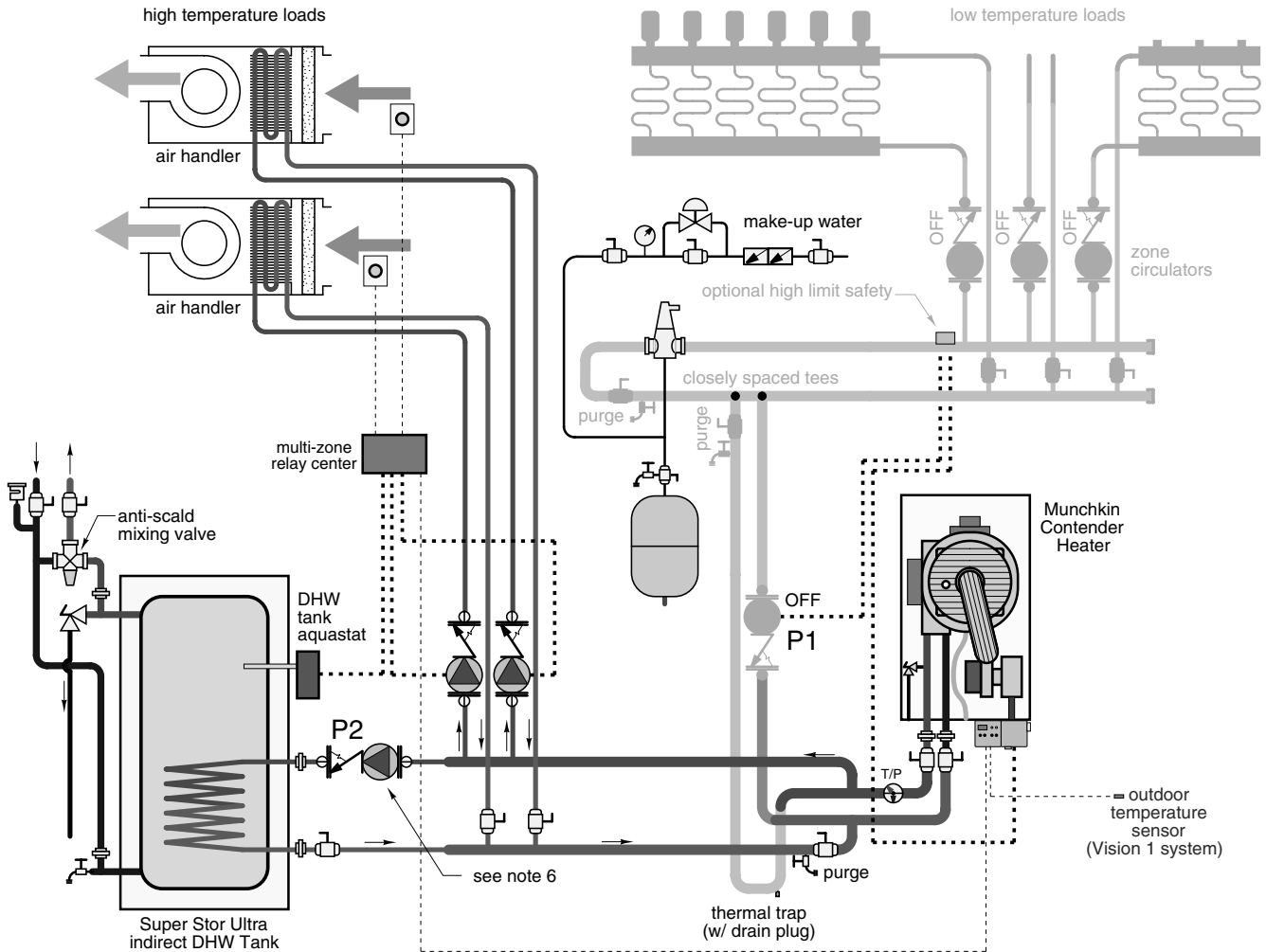


NOTES:

1. This drawing is meant to show system piping concept only. Installer is responsible for all equipment & detailing required by local codes.
2. All closely spaced tees shall be within 4 pipe diameters center to center spacing.
3. A minimum of 6 pipe diameters of straight pipe shall be installed upstream & downstream of all closely spaced tees.
4. The **minimum** pipe size for connecting a Super Stor Ultra Indirect Water Heater is 1-inch.
5. The **minimum** pipe size for connecting the Munchkin Contender is 1.25-inch
6. Circulators are shown with isolation flanges and integral check valves. The alternative is standard flanges with full port ball valves and a separate flow check valve. Purge valves can be used with the circulator flanges as an alternative.
7. Optional Vision 1 system includes temperature sensors for DHW and outdoor air and must be purchased separately.
8. The anti-scald mixing valve is recommended if the DHW temperature is set above the factory setting of 119° F.
9. Install a minimum of 12 diameters of straight pipe upstream of all circulators.
10. **Winterization:** When winterizing the Munchkin Contender, put a drain valve on both the supply and return between the union and the shut-off connection.

Munchkin Contender Heater with optional VISION 1 system  
 Multiple high temperature priority loads  
 controlled with zone circulators  
 Multiple low temperature load controls with zone circulators

Drawing 3G



NOTES:

1. This drawing is meant to show system piping concept only. Installer is responsible for all equipment & detailing required by local codes.
2. All closely spaced tees shall be within 4 pipe diameters center to center spacing.
3. A minimum of 6 pipe diameters of straight pipe shall be installed upstream & downstream of all closely spaced tees.
4. The **minimum** pipe size for connecting a Super Stor Ultra Indirect Water Heater is 1-inch.
5. The **minimum** pipe size for connecting the Munchkin Contender is 1.25-inch
6. Circulators are shown with isolation flanges and integral check valves. The alternative is standard flanges with full port ball valves and a separate flow check valve. Purge valves can be used with the circulator flanges as an alternative.
7. Optional Vision 1 system includes temperature sensors for DHW and outdoor air and must be purchased separately.
8. The anti-scald mixing valve is recommended if the DHW temperature is set above the factory setting of 119°F.
9. Install a minimum of 12 diameters of straight pipe upstream of all circulators.
10. **Winterization:** When winterizing the Munchkin Contender, put a drain valve on both the supply and return between the union and the shut-off connection.

## PART 7: VENTING, COMBUSTION AIR & CONDENSATE REMOVAL

### **DANGER**

Munchkin Contender Heater must be vented as detailed in Venting section Part 7. Ensure the exhaust and intake piping comply with these instructions regarding vent system.

Inspect finished combustion air intake and exhaust piping thoroughly to ensure all joints are well secured and airtight and comply with all applicable code requirements, as well as with the instructions provided in this manual.

Failure to provide a properly installed vent system will cause severe personal injury or death.

### A. INSTALLING EXHAUST VENT AND INTAKE AIR VENT

### **WARNING**

This vent system will operate with a positive pressure in the pipe. Do not connect vent connectors serving appliances vented by natural draft into any portion of mechanical draft systems operating under positive pressure.

Follow the venting instructions below carefully. Failure to do so may result in severe personal injury, death, or substantial property damage.

### B. GENERAL

1. Install the Munchkin Contender venting system in accordance with these instructions and with the National Fuel Gas Code, ANSI Z223.1/NFPA 54, CAN/CGA B149, and/or applicable provisions of local building codes. Vent installations in Canada must comply with ULC S636. The Recommended manufacturer for this application is Iplex of Canada Model System 636.
2. This heater is a direct vent appliance and is listed as a Category IV appliance with Underwriters Laboratories, Inc. VENT AND INTAKE AIR PIPE

### C. APPROVED MATERIALS FOR EXHAUST VENT AND INTAKE AIR VENT

1. Use only Non Foam Core venting material. The following materials are approved for use as vent pipe for this heater:

- a. Non Foam Core PVC (Polyvinyl Chloride) Pipe conforming to ASTM D-1785).
- b. Non Foam Core CPVC (Chlorinated Polyvinyl Chloride) Pipe conforming to ASTM D-1785).
- c. Non Foam Core ABS (Acrylonitrile-Butadiene- Styrene) Pipe conforming to ASTM D3965 Class 3-2-2-2.

### **WARNING**

Do not use Foam Core Pipe in any portion of the exhaust piping from this heater. Use of Foam Core Pipe may result in severe personal injury, death, or substantial property damage.

2. Cellular foam core piping may be used on air inlet piping only. Never use cellular foam core material for exhaust vent piping.

### D. EXHAUST VENT AND INTAKE AIR VENT PIPE LOCATION

### **WARNING**

Both exhaust and intake air vents must exit from the same side of the building to assure correct appliance operation.

#### 1. Determine exhaust vent location:

- a. The vent piping for this heater is approved for zero clearance to combustible construction.
- b. See illustration within this section of clearances for location of exit terminals of direct-vent venting systems.
- c. This heater vent system shall terminate at least 3 feet (0.9 m) above any forced air intake located within 10 ft (3 m). Note: this does not apply to the combustion air intake of a direct-vent appliance.
- d. Provide a minimum of 1 foot distance from any door, operable window, or gravity intake into any building.
- e. Provide a minimum of 1 foot clearance from the bottom of the exhaust above the expected snow accumulation level. Snow removal may be necessary to maintain clearance.

**PART 7: VENTING, COMBUSTION AIR & CONDENSATE REMOVAL (CONTINUED)**

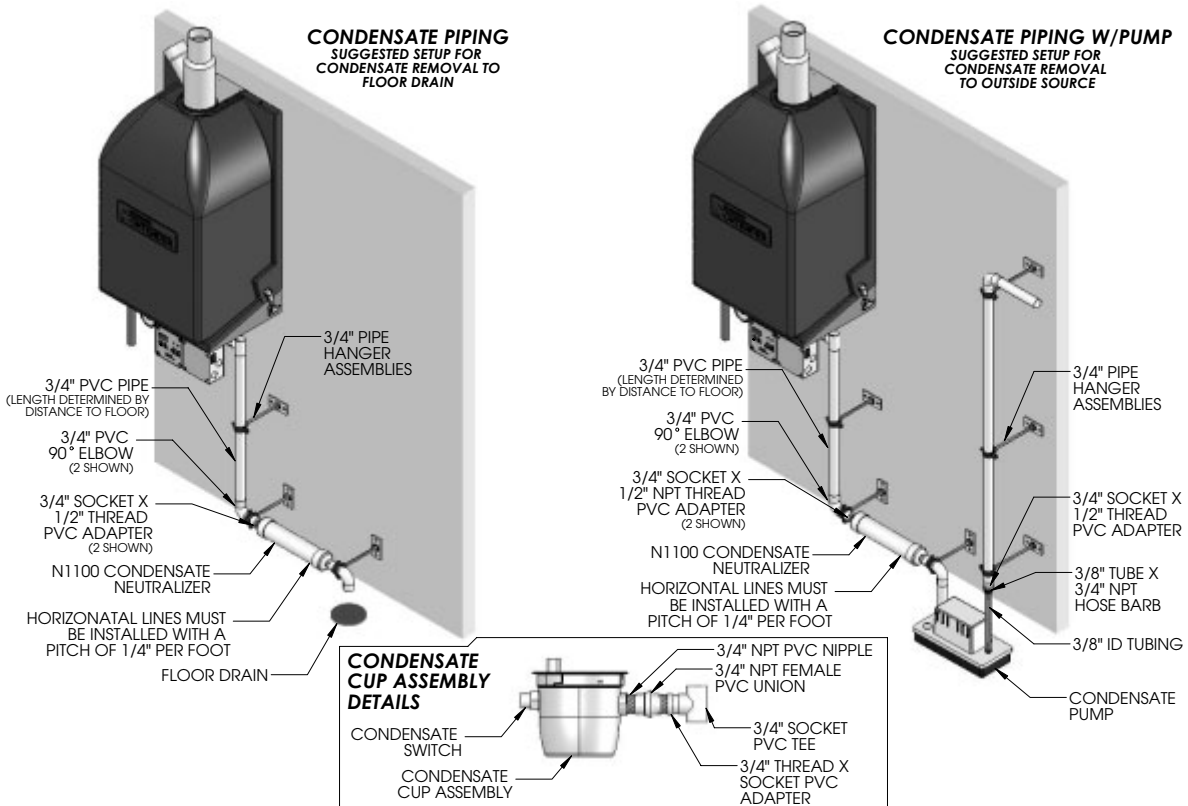
- f. Provide 4 feet horizontal clearance from electrical meters, gas meters, gas regulators and relief equipment. In no case shall the exit terminal be above or below the aforementioned equipment unless the 4 foot horizontal distance is maintained.
- g. Do not locate the exhaust over public walkways where condensate could drip and/or freeze and create a nuisance or hazard.
- h. The vent for this appliance shall not terminate over public walkways; or near soffit vents or crawl space vents or other area where condensate or vapor could create a nuisance or hazard or cause property damage; or where condensate or vapor could cause damage or could be detrimental to the operation of regulators, relief valves, or other equipment.
- i. Do not locate the exhaust directly under roof overhangs to prevent icicles from forming.
- j. Provide 4 feet clearance from the inside

corner of vertical walls, chimneys, etc., as well as horizontal corners created by roof overhangs.

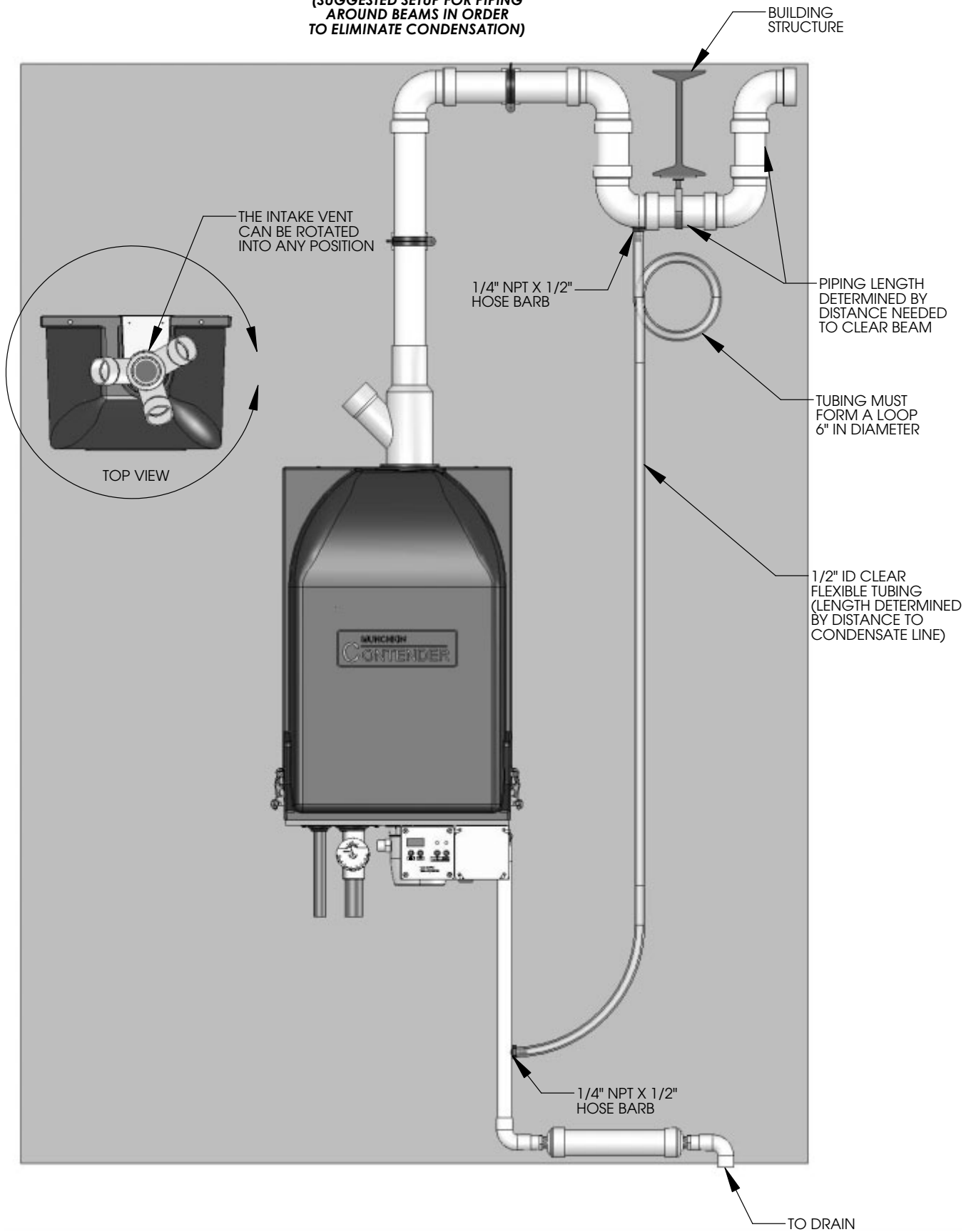
**2. Determine air intake vent location.**

- a. Provide 1 foot clearance from the bottom of the intake air vent and the level of maximum snow accumulation. Snow removal may be necessary to maintain clearances.
- b. Do not locate intake air vent in a parking area where machinery may damage the pipe.
- c. When venting with a two pipe system, maximum distance between intake air vent and exhaust vent is 6 feet (1.8 m). Minimum distance between exhaust vent and intake air vent on single heater is 8" (0.2 m) center-to-center. Minimum distance between exhaust vents and intake air vents on multiple heaters is 8" (0.2 m) center-to-center.

**E. EXHAUST VENT AND INTAKE AIR VENT SIZING**



**EXHAUST PIPING  
AROUND OBSTRUCTIONS  
(SUGGESTED SETUP FOR PIPING  
AROUND BEAMS IN ORDER  
TO ELIMINATE CONDENSATION)**



**Location of exit terminals of mechanical draft and direct-vent venting systems.**

(Reference: National Fuel Gas Code ANSI Z223.1/NFPA 54 2002).

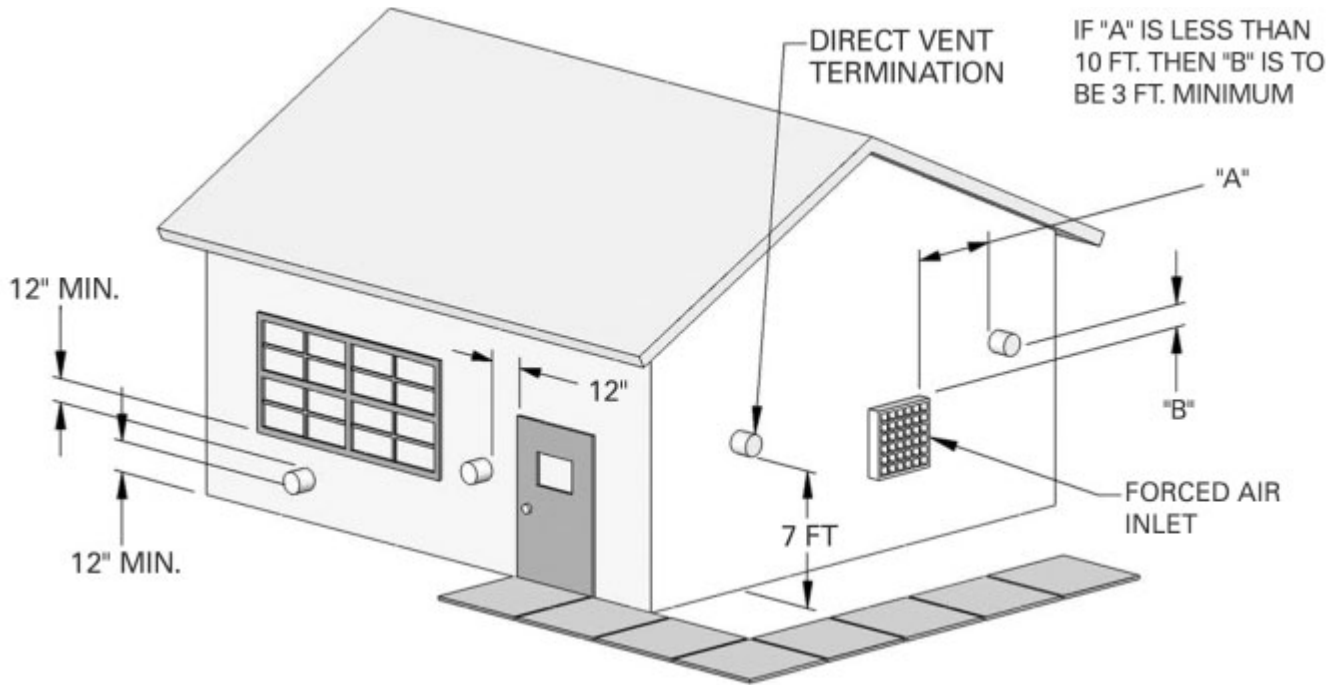


Fig. 7-1

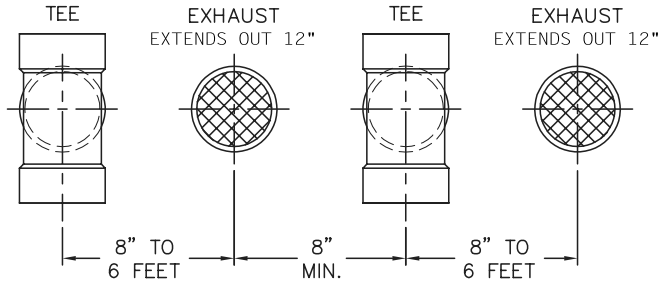


Fig. 7-2 Multiple Vent Spacing\*

\*Note: Exhaust must extend out 1 foot

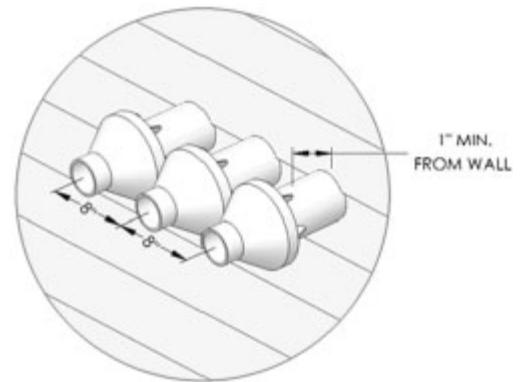


Figure 7-4: Multiple Heater Installations

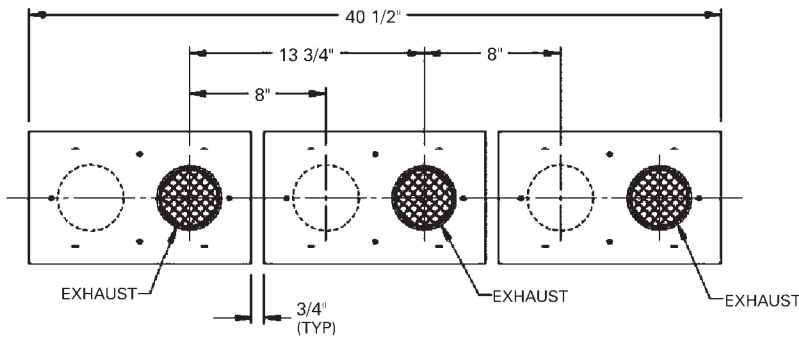


Fig. 7-3 Multiple Stainless Steel Horizontal Vent Kit Installation – Front View



**PART 7: VENTING, COMBUSTION AIR & CONDENSATE REMOVAL (CONTINUED)**

1. The exhaust vent and intake air vent pipes should be 2" or greater, Schedule 40 or 80.
2. The total combined equivalent length of exhaust vent and intake air pipe should not exceed 85 feet for 2" and 125' for 3".
  - a. The equivalent length of elbows, tees, and other fittings are listed in the Friction Loss Table 7.6.

\*Friction loss for long radius elbow is 1 foot less.

- b. For example: If the exhaust vent has two

**Table 7.6**

FRICTION LOSS EQUIVALENT IN PIPING AND FITTINGS		
FITTINGS OR PIPING	EQUIVALENT FEET	
	2"	3"
90 DEGREE ELBOW*	5'	5'
45 DEGREE ELBOW	3'	3'
COUPLING	0'	0'
AIR INLET TEE	0'	0'
STRAIGHT PIPE	1'	1'
CONCENTRIC VENT KIT	3'	3'
V500 2" VENT KIT	1'	N/A
V1000 3" VENT KIT	N/A	1'

90° elbows and 10 feet of PVC pipe we will calculate:

Exhaust Vent Pipe Equivalent Length = (2x5)+10=20 feet

Further, if the intake air vent pipe has two 90° elbows, one 45° elbow and 10 feet of PVC pipe, the following calculation applies:

Intake Air Vent Pipe Equivalent Length = (2x5)+3+10=23 feet

Finally, if a concentric vent kit is used we find:

Total Combined Equivalent Length = 20+23+3=46 feet

Therefore, the total combined equivalent length is 46 feet which is well below the maximum of 85 feet.

- c. The intake air vent pipe and the exhaust vent are intended to penetrate the same wall or roof of the building.
- d. Effort should be made to keep a minimum difference in equivalent length between the intake air vent pipe and the

exhaust vent.

3. The minimum combined equivalent length is 16 equivalent feet.
4. The maximum combined equivalent length can be extended by increasing the diameter of both exhaust vent and intake air vent pipe equally. However, the transitions should begin a minimum of 15 equivalent feet from the heater.
  - a. Transitions should always be made in vertical sections of pipe to prevent the condensate from pooling in the vent pipe.
  - b. Use a 3" x 2" reducing coupling to transition from the 2" connections to a 3" vent.
  - c. The maximum equivalent length for the increased diameter vent pipes is 125 feet.
  - d. If the transition occurs at a distance greater than 15 equivalent feet from the heater, the maximum equivalent length will be reduced. See Table 7.7. The standard Vent Pipe for Munchkin Contender is 2".

**F. EXHAUST VENT AND INTAKE AIR PIPE**

**Table 7.7: Vent Termination Kits**

Transition Point (ft from heater)	TEL of Standard 2" Vent Pipe (ft)	TEL of Oversized 2" or 3" Vent Pipe (ft)	Maximum TEL of all Vent Pipe (ft)
15	30	95	125
20	40	77-1/2	117-1/2
25	50	60-1/2	110-1/2
30	60	43	103
35	70	26	96
40	80	8-1/2	88-1/2
None	85	0	85

TEL = Total Equivalent Length

**INSTALLATION**

1. On the Munchkin Contender the 2" exhaust vent connection is located on the top, right side of the unit and the air intake is on the top, left side. Sealant or adhesive is required for all fittings.
2. Use only solid PVC, CPVC, or ABS schedule

**PART 7: VENTING, COMBUSTION AIR & CONDENSATE REMOVAL (CONTINUED)**

40 or 80 pipe. FOAM CORE PIPING IS NOT APPROVED.

3. Remove all burrs and debris from joints and fittings.
4. All joints must be properly cleaned, primed, and cemented. Use only cement and primer approved for use with the pipe material. Cement must conform to ASTM D2564 for PVC or CPVC pipe and ASTM D2235 for ABS pipe.
5. Horizontal lengths of exhaust vent must slope

**⚠ WARNING**

**All joints of positive pressure vent systems must be sealed completely to prevent leakage of flue products into the living space.**

back towards the heater not less than 1/4" per foot to allow condensate to drain from the vent pipe. If the exhaust pipe must be piped around an obstacle that results in the creation of a low point, condensate will collect in this low point and form a blockage. This condensate must be drained away using a field-installed condensate drain assembly as shown.

6. All piping must be fully supported. Use pipe hangers at a minimum of 4 foot intervals to prevent sagging of the pipe where condensate may form.
7. Do not use the Munchkin Contender to support any piping.
8. A screened straight coupling is provided with the heater for use as an outside exhaust termination.
9. A screened inlet air tee is provided with the heater to be used as an outside intake termination.
10. The following information on Table 7.8 are optional intake air/exhaust vent terminations available from Heat Transfer Products, Inc.

**Table 7.8: Vent Termination Kits**

Description	Stock Code
2" PVC Concentric Vent Termination Kit	KGAVT0501CVT
3" PVC Concentric Vent Termination Kit	KGAVT0601CVT
2" Stainless Steel Vent Termination Kit	V500
3" Stainless Steel Vent Termination Kit	V1000

**G. HEATER REMOVAL FROM A COMMON VENT SYSTEM**

At the time of removal of an existing heater, the following steps shall be followed with each appliance remaining connected to the common venting system placed in operation, while the other appliances remaining connected to common venting system are not operating.

1. Seal any unused openings in the common venting system.
2. Visually inspect the venting system for proper size and horizontal pitch to determine if there is blockage, leakage, corrosion or other deficiencies that could cause an unsafe condition.
3. If practical, close all building doors, windows and all doors between the space in which the appliance remains connected to the common venting system located and other spaces in the building. Turn on clothes dryers and any appliances not connected to the common venting system. Turn on any exhaust fans, such as range hoods and bathroom exhausts, at maximum speed. Do not operate a summer exhaust fan. Close all fireplace dampers.
4. Place in operation the appliance being inspected. Follow the lighting instructions. Adjust the thermostat so the appliance will operate continuously.
5. Test for spillage at the draft hood relief opening after 5 minutes of main burner operation. Use the flame of a match or candle or smoke from a cigarette.
6. After it has been determined that each appliance remaining connected to common venting system properly vents when tested as outlined, return doors, windows, exhaust fans, fireplace dampers and any other gas burning appliance to their previous condition of use.
7. Any improper operation of the common venting system should be corrected so the installation conforms with the National Fuel Gas Code, ANSI Z223.1. When resizing any portion of the common venting system, the common venting system should be resized to approach the minimum size as determined using the appropriate tables in Appendix G in the National Fuel Gas Code , ANSI Z 223.1

**PART 7: VENTING, COMBUSTION AIR & CONDENSATE REMOVAL (CONTINUED)**

**H. CONDENSATE REMOVAL SYSTEM**

This is a condensing high efficiency appliance, therefore this unit has a condensate removal system. Condensate is nothing more than water vapor, derived from the combustion products, similar to an automobile when it is initially started. It is very important that the condensate line is sloped away from the heater and down to a suitable inside drain, if the condensate outlet on the Munchkin Contender is lower than the drain, you must use a condensate removal pump (kit P/N 554200 available from Heat Transfer Products, Inc.) A condensate filter, if required by local authorities can be made up of lime crystals, marble or phosphate chips will neutralize the condensate. This can be done in the field by the installer or you may purchase one from Heat Transfer Products, Inc. (P/N N1100) It is also very important that the condensate line is not exposed to freezing temperatures, or any other type of blockage. Plastic tubing should be the only material used for the condensate line. Steel, brass, copper or others will be subject to corrosion or deterioration. A second vent may be necessary to prevent condensate line vacuum lock if a long horizontal run is used. Also, an increase in pipe size may be necessary to drain properly. Support of the condensation line may be necessary to avoid blockage of the condensate flow.

**CAUTION**

**The condensate line must remain unobstructed, allowing free flow of condensate. If condensate is allowed to freeze in the line or if the line is obstructed in any other manor, condensate can exit from the heater tee, resulting in potential water damage to property.**

**NOTICE**

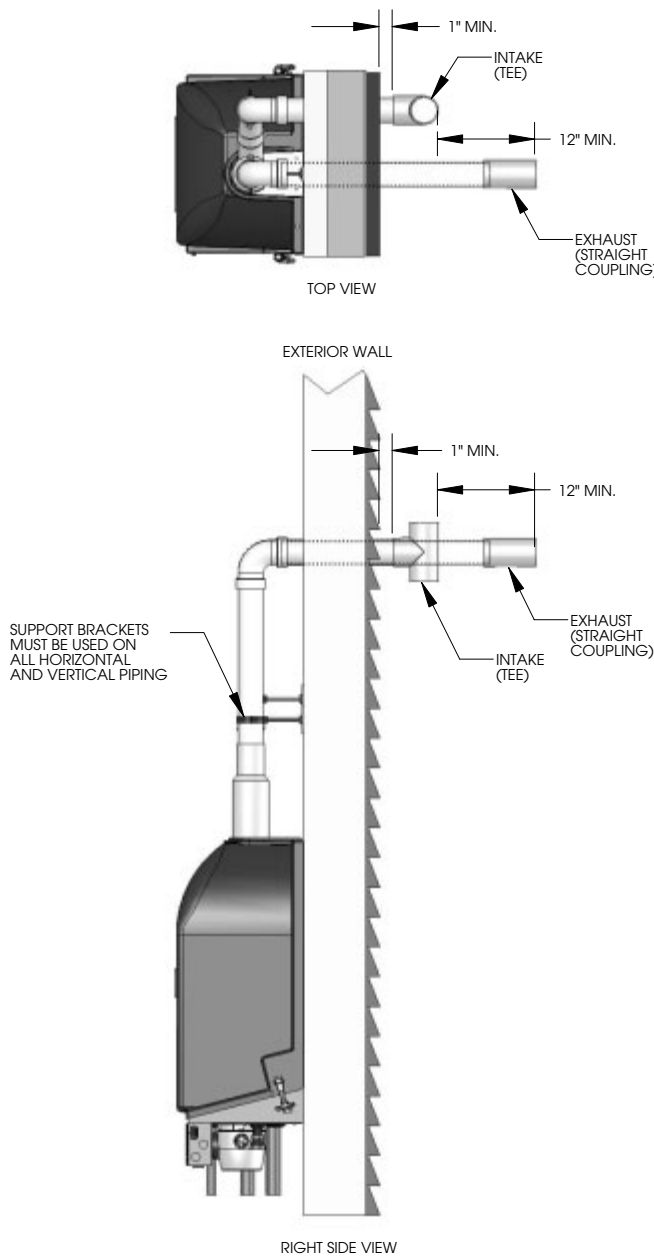
**Use materials approved by the authority having jurisdiction. In the absence of other authority, PVC and CPVC pipe must comply with ASTM D1785 or D1784, F441 or D2665. Cement and primer must comply with ASTM D2564 or F493. For Canada, use CSA or ULC certified PVC or CPVC pipe, fittings and cement. (See Table 7-9) When installing a condensate pump, select one approved for use with condensing heaters and furnaces. The pump should have an overflow switch to prevent property damage from condensate spillage.**

**Condensate from the Munchkin Contender Heater will be slightly acidic (typically with a pH from 3.2 to 4.5). Install a neutralizing filter if required by local codes.**

**Table 7-9**

Item	Material	United States	Canada
Vent or air pipe and fitting	PVC schedule 40	ANSI/ASTM D1785	ULC S636 certified only
	PVC-DWV	ANSI/ASTM D2665	
	CPVC schedule 40	ANSI/ASTM F441	
	ABS-DWV schedule 40	ANSI/ASTM D2661	
Pipe cement/primer	PVC	ANSI/ASTM D2564	
	CPVC	ANSI/ASTM F493	
	ABS	ANSI/ASTM D2235	

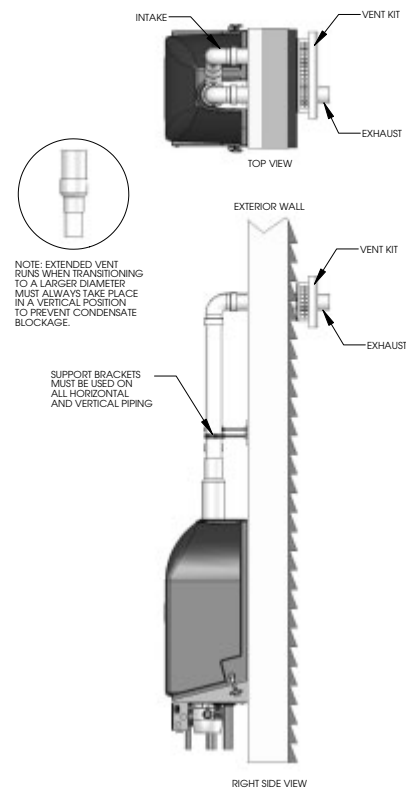
**I. DIAGRAMS FOR SIDEWALL VENTING**



**Fig. 7-9 2" sidewall vent with tee (intake) and coupling (exhaust)**

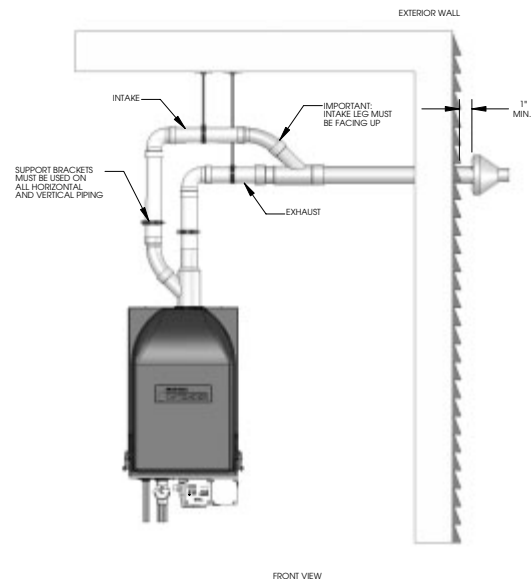
**\*\*Important Note:** All vent pipes must be glued, properly supported, and the exhaust must be pitched a minimum of a 1/4" per foot back to the heater (to allow for drainage of condensate).

**SIDEWALL VENTING WITH KIT**



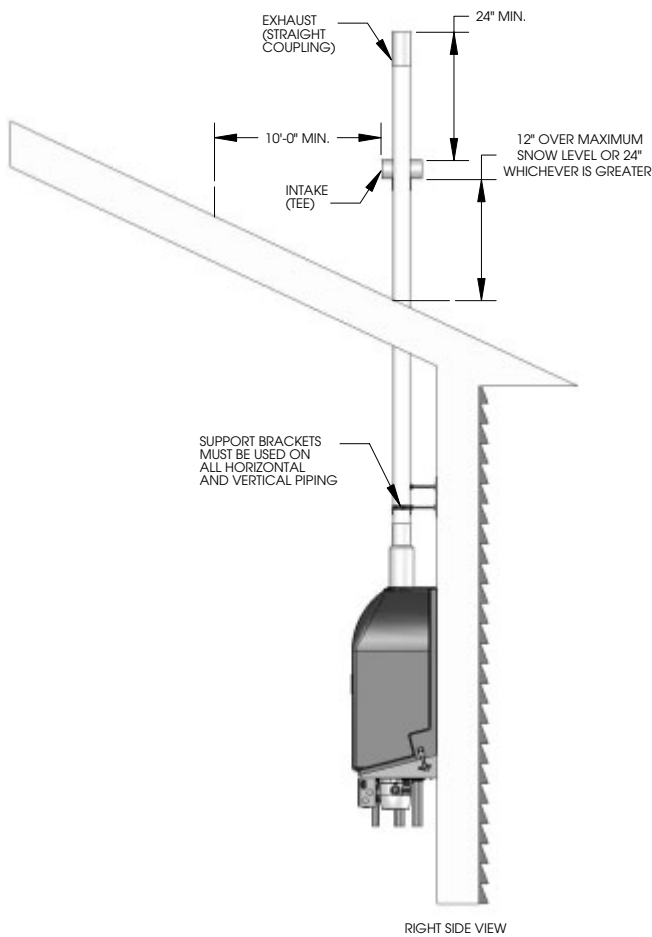
**Fig. 7-10 2" sidewall vent with V500 kit**

**SIDEWALL VENT WITH CONCENTRIC VENT KIT**

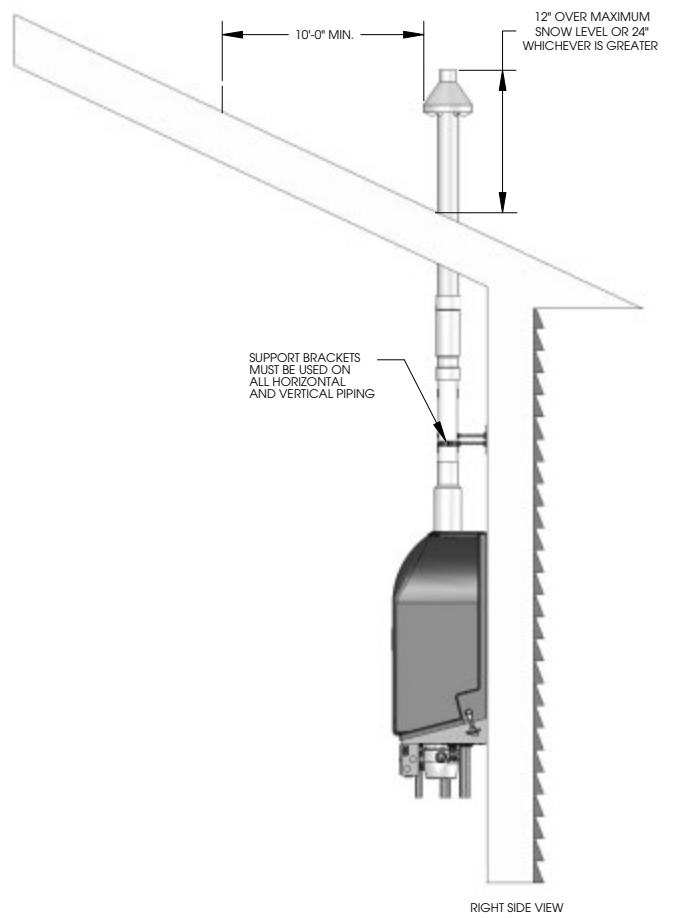


**Fig. 7-11 2" sidewall vent with 2" concentric vent kit (KGAVT0501CVT)**

**NOTE:** When placing support brackets on vent piping, the first bracket must be within 1 foot of the appliance and the balance at 4 foot intervals on the vent pipe. The heater venting must be readily accessible for visual inspection for the first three feet from the heater.



**Fig. 7-12 2" roof vent with tee (intake) & coupling (exhaust)**



**Fig. 7-13 2" roof vent with 2" concentric vent kit (KGAVT0501CVT)**

**NOTE:** When placing support brackets on vent piping, the first bracket must be within 1 foot of the appliance and the balance at 4 foot intervals on the vent pipe. The heater venting must be readily accessible for visual inspection for the first three feet from the heater.

## PART 8: GAS PIPING

### **! WARNING**

Failure to follow all precautions could result in fire, explosion or death!

#### A. GAS CONNECTION

The gas supply shall have a maximum inlet pressure of less than 14" water column (350 mm), 1/2 pound pressure (3.5 kPa), and a minimum of 3.5" water column.

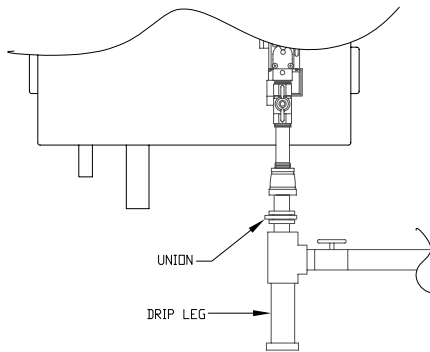


Fig. 8-1

The entire piping system, gas meter and regulator must be sized properly to prevent pressure drop greater than 0.5" as stated in the National Fuel Gas Code. This information is listed on the rating plate. It is very important that you are connected to the type of gas as noted on the rating plate. "LP" for liquefied petroleum, propane gas or, "Nat" natural or city gas. All gas connections must be approved by the local gas supplier, or utility in addition to the governing authority, prior to turning the gas supply on. The nipple provided is 1/2" with a factory installed. Do not remove this 3/4" x 1/2" bell reducer! It is mandatory that this fitting is used for connection to a field fabricated drip leg as shown in the illustration above per the National Fuel Gas Code. You must ensure that the entire gas line to the connection at the Munchkin Contender is no smaller than 3/4". Once all the inspections have been performed, the piping must be leak tested. If the leak test requirement is a higher test pressure than the maximum inlet pressure, you must isolate the Munchkin Contender from the gas line. In order to do this, you must shut the gas off using factory and field-installed gas cocks. This will prevent high pressure. Failure to do so may damage the gas valve. In the event the gas valve is exposed to a pressure greater than 1/2 PSI, 14" water column, the gas valve must be replaced. Never use an open flame (match, lighter, etc.) to check gas connections.

#### B. GAS PIPING

1. Run the gas supply line in accordance with all applicable codes.
2. Locate and install manual shutoff valves in accordance with state and local requirements.

#### C. GAS TABLE

Refer to Table 8.2 to size the supply piping to minimize pressure drop between meter or regulator and unit.

Maximum Capacity of Pipe in Cubic Feet of Gas per Hour for Gas Pressures of 0.5 psi or Less and a Pressure Drop of 0.3 Inch water Column

(TABLE 8-2) (Based on a 0.60 Specific Gravity Gas)

Nominal Iron Pipe Size (inches)	Internal Diameter (inches)	Length of Pipe (Feet)															
		10	20	30	40	50	60	70	80								
3/4	.824	278	190	152	130	115	105	96		BTU'S PER HOUR x1,000							
1	1.049	520	350	285	245	215	195	180									
1 1/4	1.380	1,050	730	590	500	440	400	370									
1 1/2	1.610	1,600	1,100	890	760	670	610	560									
									80	90	100	125	150	175	200		
3/4	.824	90	84	79	72	64	59	55		BTU'S PER HOUR x1,000							
1	1.049	170	160	150	130	120	110	100									
1 1/4	1.380	350	320	305	275	250	225	210									
1 1/2	1.610	530	490	460	410	380	350	320									

It is recommended that a soapy solution be used to detect leaks. Bubbles will appear on the pipe to indicate a leak is present. The gas piping must be sized for the proper flow and length of pipe, to avoid pressure drop. Both the gas meter and the gas regulator must be properly sized for the total gas load. If you experience a pressure drop greater than 1" WC, the meter, regulator or gas line is undersized or in need of service. You can attach a manometer to the incoming gas drip leg, by removing the cap and installing the manometer. The gas pressure must remain between 3.5" and 14" during stand-by (static) mode and while in operating (dynamic) mode. **If an in-line regulator is used, it must be a minimum of 10 feet from the Munchkin**

**PART 8: GAS PIPING (CONTINUED)**

**Contender.** It is very important that the gas line is properly purged by the gas supplier or utility. Failure to properly purge the lines or improper line sizing, will result in ignition failure. This problem is especially noticeable in NEW LP installations and also in empty tank situations. This can also occur when a utility company shuts

off service to an area to provide maintenance to their lines. This gas valve must not be replaced with a conventional gas valve under any circumstances. As an additional safety feature, this gas valve has a flanged connection to the swirl plate and blower.

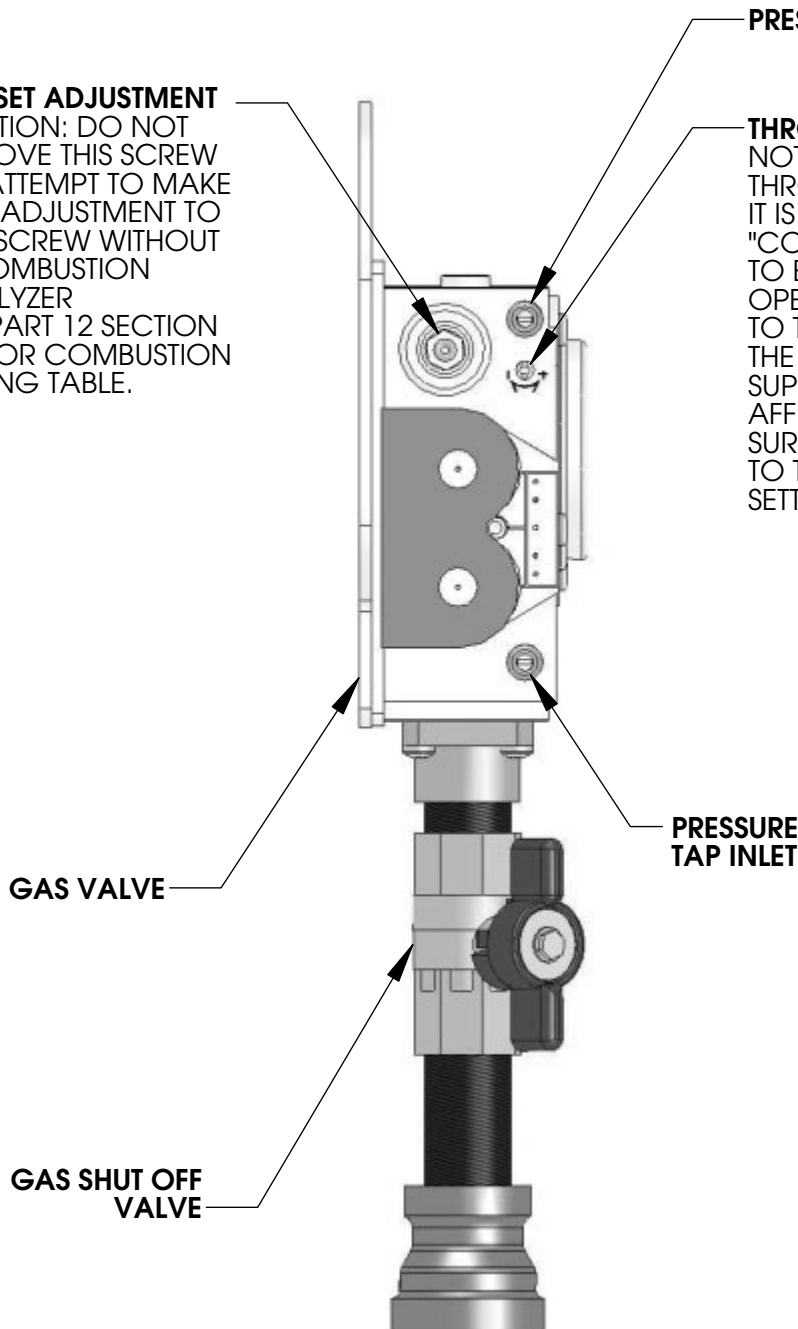
**D. DUNGS GAS VALVE**

**OFF SET ADJUSTMENT**  
CAUTION: DO NOT REMOVE THIS SCREW OR ATTEMPT TO MAKE ANY ADJUSTMENT TO THIS SCREW WITHOUT A COMBUSTION ANALYZER  
SEE PART 12 SECTION "D" FOR COMBUSTION SETTING TABLE.

**PRESSURE TAP OUTLET**

**THROTTLE ADJUSTER**

NOTE: IF FOR ANY REASON THE THROTTLE NEEDS TO BE ADJUSTED, IT IS VERY IMPORTANT THAT A "COMBUSTION ANALYZER" BE USED TO ENSURE SAFE AND PROPER OPERATION. TURN THE ADJUSTER TO THE (+) TO INCREASE GAS OR THE (-) TO DECREASE THE GAS SUPPLY. THIS ADJUSTMENT COULD AFFECT CO/CO% LEVELS. MAKE SURE THE LEVELS CORRESPOND TO THE CHART IN COMBUSTION SETTINGS. SEE PART 12 SECTION "D"



**⚠ WARNING**

For a heater already installed, you must turn off gas supply, turn off power and allow heater to cool before proceeding. You must also completely test the heater after conversion to verify performance as described under "Startup" section of this manual. See separate natural to propane conversion instructions for conversion of an existing heater available from Heat Transfer Products. Failure to comply with the proper gas conversion instructions could result in severe personal injury, death or substantial property damage. Failure to follow all precautions could result in fire, explosion or death!

Fig. 8-3

## PART 9: FIELD WIRING

### WARNING

**ELECTRICAL SHOCK HAZARD** — For your safety, turn off electrical power supply at service entrance panel before making any electrical connections to avoid possible electric shock hazard. Failure to do so can cause severe personal injury or death.

### NOTICE

**Wiring must be N.E.C. Class 1.**  
If original wiring as supplied with heater must be replaced, use only TEW 105 °C wire or equivalent.  
Heater must be electrically grounded as required by National Electrical Code ANSI/NFPA 70 — latest edition.

#### A. INSTALLATION MUST COMPLY WITH:

1. National Electrical Code and any other national, state, provincial or local codes or regulations.
2. In Canada, CSA C22.1 Canadian Electrical Code Part 1, and any local codes.

#### B. FIELD WIRING

For your convenience we have located the electrical connection of the Munchkin Contender on the

front right hand side of the unit. The electrical junction box has a 24 volt terminal compartment and 120 volt terminal compartment. Each terminal connection is clearly marked to assure correct installation.

#### C. LINE VOLTAGE WIRING

1. Connect 120 VAC power wiring to the line voltage terminal strip located inside the electric junction box, as shown in figure 9.5.
2. Wire the Heater Primary Circulator (P1) to the terminal strip. See wiring diagram in this section.

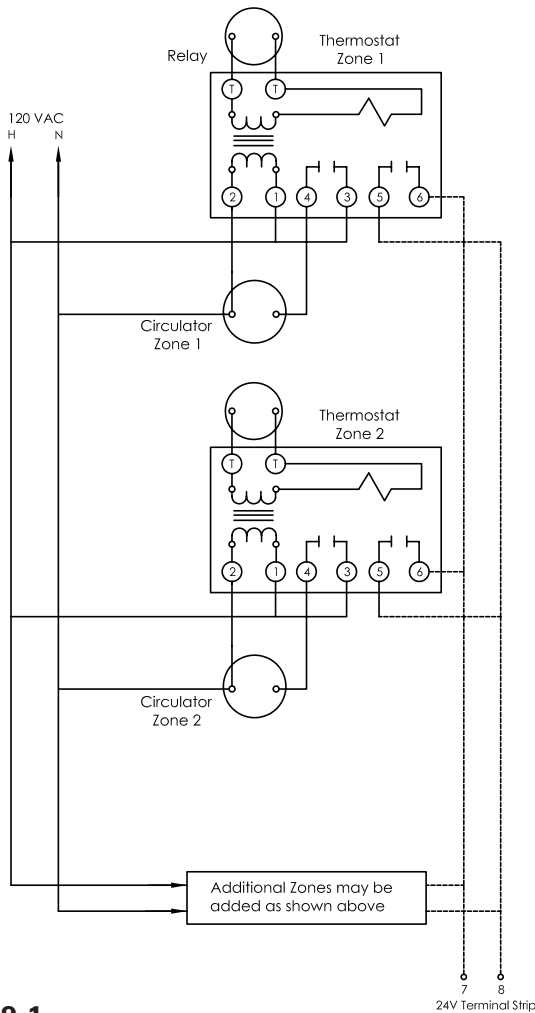
#### D. THERMOSTAT

1. Connect room thermostat or end switch
2. Install thermostat on inside wall away from influences of drafts, hot or cold water pipes, lighting fixtures, television, sunrays or fireplaces.
3. Thermostat anticipator (if applicable):
  - a. If connected directly to heater, set for 0.1 amps.
  - b. If connected to relays or other devices, set to match total electrical power requirements of connected devices. See specifications of the device and thermostat instructions for details.

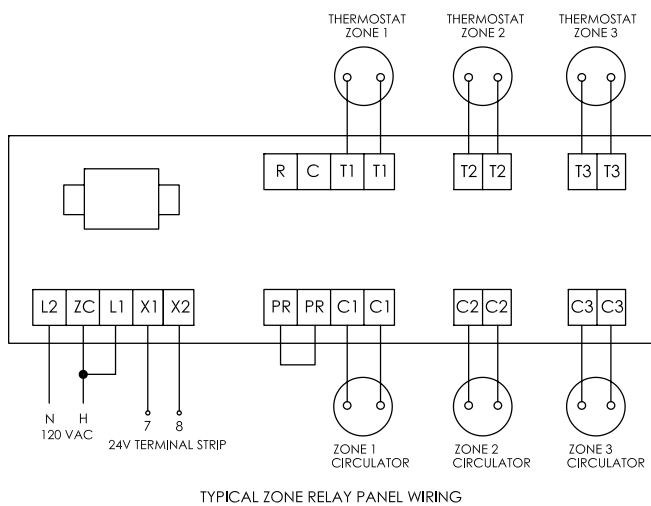


**PART 9: FIELD WIRING (CONTINUED)**

FIELD WIRING WITH ZONE CIRCULATORS

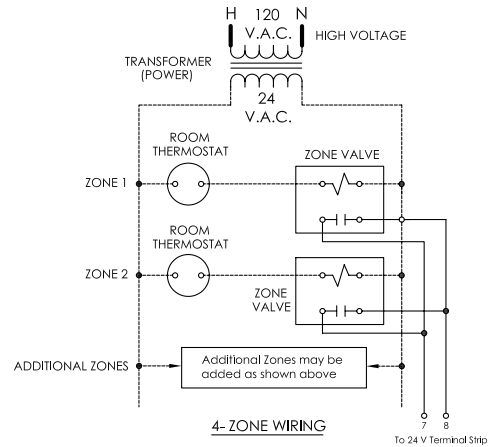


**Fig. 9-1**

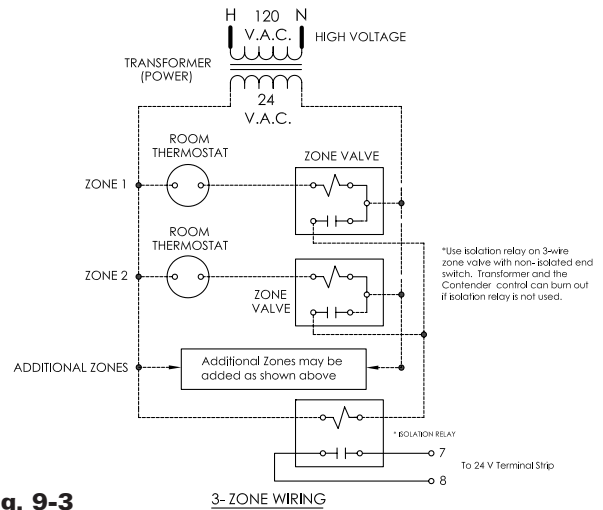


TYPICAL ZONE RELAY PANEL WIRING

**Fig. 9-2**

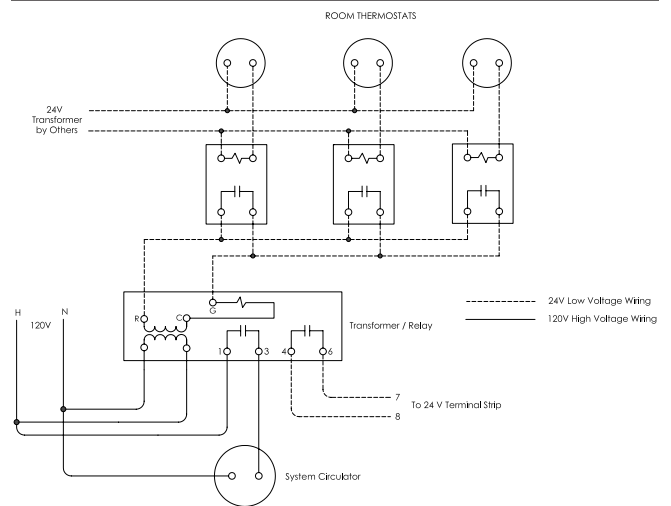


4-ZONE WIRING



3-ZONE WIRING

**Fig. 9-3**

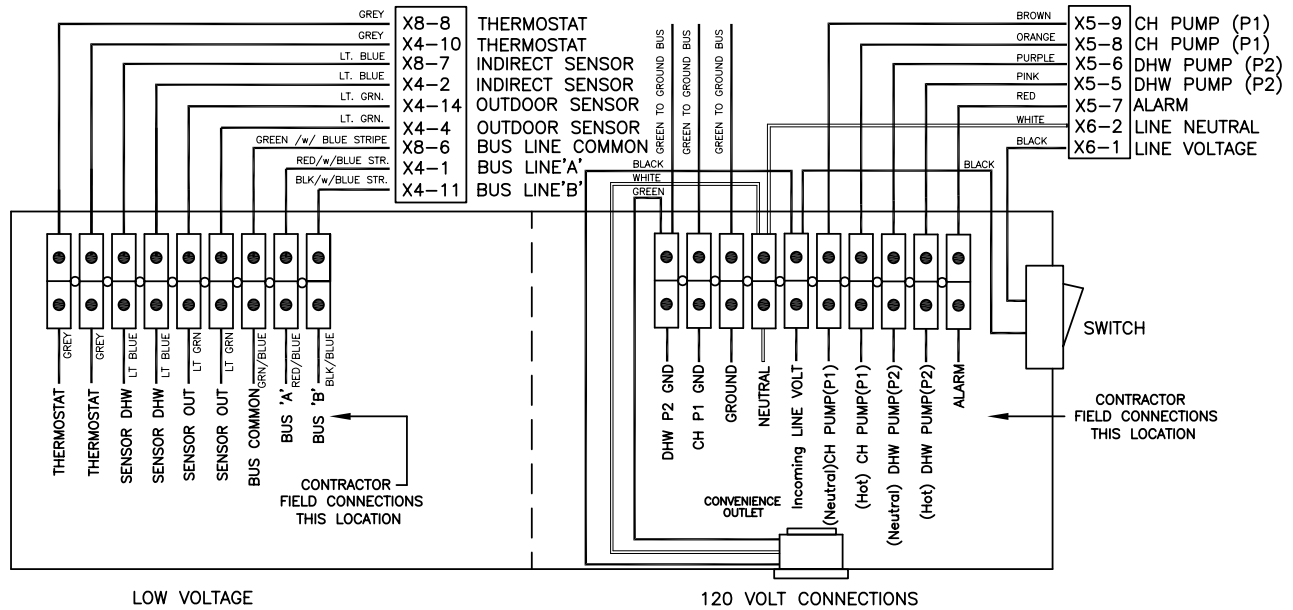


SECONDARY SYSTEM CIRCULATOR WIRING

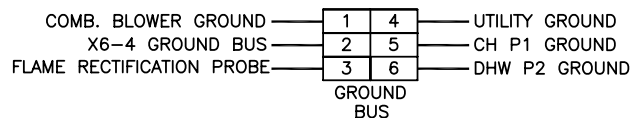
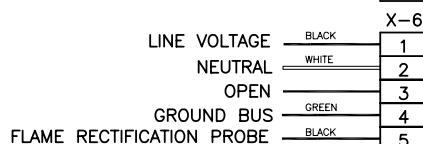
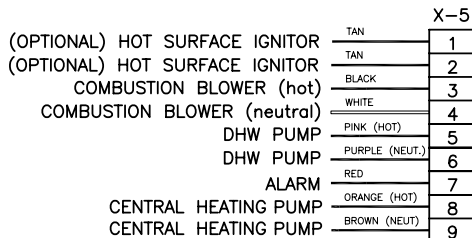
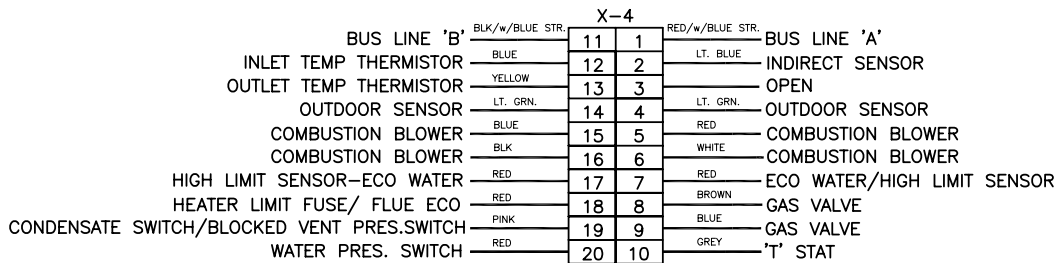
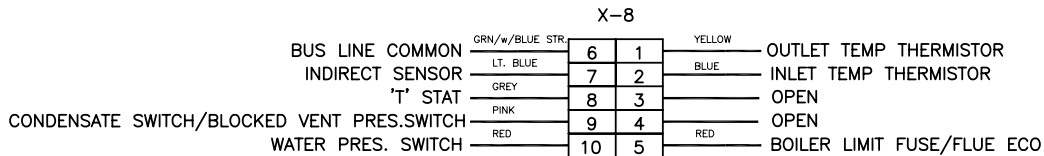
**Fig. 9-4**

**PART 9: FIELD WIRING (CONTINUED)**

Munchkin Contender  
Field Wiring Diagram



Munchkin Contender  
Internal Wiring Diagram



**Fig. 9-5**

## PART 10: FIELD WIRING – VISION 1 OPTION

**Outdoor Sensor Function** The user can program the desired supply temperature based on the heat transmitter (Baseboard, Radiant Floor, Air Handler) that will be used in the installation. Once the outdoor sensor (Light Green Wires) is connected to the control board, the water temperature of the heater will adjust to run the heater more efficiently and provide greater comfort to the living space.

**Connection Specification – Wire 22 AWG maximum to 100 feet or 18 AWG up to 150 feet. Length of wire run cannot exceed 150 feet.**

**Outdoor Sensor** is connected in the junction box on the Munchkin Contender. Route wires from the Munchkin Contender terminal strip to your outdoor sensor, which will allow the user to change the temperature going to the Central Heating loop automatically. Place the outdoor sensor preferably to the north or northwest or to the side which will be affected by changing weather conditions outside. NOTE: Do not locate the sensor in the direct sunlight.

### CAUTION

The wire to outdoor sensor must not be laid closer than 6' to line voltage wiring (120/240 V) and must never be in the same conduit.

**Indirect Sensor Function:** The Maximum run time on priority function for the Super Stor Ultra Indirect Fired Water Heater is from 1-60 minutes. The water temperature can only be adjusted when using a sensor (not a mechanical control). Temperature adjustments are from 95 to 185 degrees, plus a differential 1-18 degrees (Note: It is recommend that you do not exceed 5 minutes on the DHW pump post purge cycle to avoid cooling down your DHW tank).

**Indirect Sensor** is connected to the main control on the Munchkin Contender. Route wires from the terminal strip to the sensor or the mechanical control Honeywell Part # L4080b-

1395 (Not included in Vision I Package) into the control well located in the front of the water heater. This will allow the installer to control the temperature of the indirect from the Munchkin Contender and give the water heater priority over the Central Heating Circuit. Once the Water Heater is satisfied, the heater will then switch back to the Central Heating Circuit only if there is a call for heat, otherwise the Munchkin Contender will then shut down.

**Indirect Circulator (P2) Program function:** The indirect water heater circulator program function will automatically start when the water heater sensor reads a call for heat, the installer can also program the post purge function on the circulator. The Post purge circulator function ranges from 1-30 minutes.

**Indirect Circulator (P2)** is connected to the terminal strip on the Munchkin Contender. Run the wire to the Super Stor Ultra Indirect circulating pump. The purple wire will be your neutral lead and the pink wire will be your hot. This will supply 120 volts to the water heater circulator directly.

**Fault Code Alarm Output** is connected to the main controller on the Munchkin Contender. Route wire from the Munchkin Contender controller to an external relay or an audible alarm. The red wire will be your hot lead supplying 120 volts. The neutral connection will be connected to the neutral on the incoming power to the Munchkin Contender.

### CAUTION

Do not tie neutrals or hot wire leads to any other wires, go directly from the Munchkin Contender controller to the circulator.

**Connection Specification – Wire 18 AWG maximum. Length of wire run cannot exceed 100 feet.**

## PART 11. START-UP PREPARATION

### A. CHECK/CONTROL WATER CHEMISTRY

#### **WARNING**

Do not use petroleum-based cleaning or sealing compounds in heater system. Damage to elastomer seals and gaskets in system could occur, resulting in substantial property damage.

#### **Water pH between 6.0 and 8.0**

1. Maintain heater water pH between 6.0 and 8.0. Check with litmus paper or have chemically analyzed by water treatment company.
2. If pH differs from above, consult local water treatment company for treatment needed.

#### **Hardness less than 7 grains.**

1. Consult local water treatment companies for unusually hard water areas (above 7 grains hardness).

#### **Chlorine concentration less than 200 ppm**

1. Filling with chlorinated fresh water should be acceptable since drinking water chlorine levels are typically less than 5 ppm.
2. Do not use the heater to directly heat swimming pool or spa water.
3. Do not fill heater or operate with water containing chlorine in excess of 200 ppm.

#### **Clean system to remove sediment**

1. You must thoroughly flush the system (without heater connected) to remove sediment. The high-efficiency heat exchanger can be damaged by buildup or corrosion due to sediment.
2. For zoned systems, flush each zone separately through a purge valve. (If purge valves and isolation valves are not already installed, install them to properly clean the system.)
3. Flush system until water runs clean and you are sure piping is free of sediment.

#### **Test/replace freeze protection fluid**

1. For systems using freeze protection fluids, follow fluid manufacturer's instructions to verify inhibitor level and that other fluid characteristics are satisfactory.
2. Freeze protection fluid must be replaced periodically due to degradation of inhibitors over time. Follow all fluid manufacturer's instructions.

### B. FREEZE PROTECTION (WHEN USED)

#### **WARNING**

**NEVER** use automotive or standard glycol antifreeze, even ethylene glycol made for hydronic systems. Use only freeze-prevention fluids certified by fluid manufacturer as suitable for use with stainless steel heaters, verified in fluid manufacturer's literature.

**Thoroughly clean and flush any system that has used glycol before installing the new Contender Contender Heater.**

**Provide Munchkin Contender Heater owner with a material safety data sheet (MSDS) on the fluid used.**

1. Determine freeze protection fluid quantity using total system water content, following fluid manufacturer's instructions. Remember to include expansion tank water content.
2. Local codes may require back flow preventer or actual disconnect from city water supply.
3. When using freeze protection fluid with automatic fill, install a water meter to monitor water makeup. Freeze protection fluid may leak before the water begins to leak, causing concentration to drop, reducing the freeze protection level.

### C. FILL AND TEST WATER SYSTEM

1. Fill system only after ensuring the water meets the requirements of this manual.
2. Close manual and automatic air vents and heater drain valve.
3. Fill to correct system pressure. Correct pressure will vary with each application.
  - a. Typical cold water fill pressure for a residential system is 12 psi.
  - b. Pressure will rise when heater is turned on and system water temperature increases. Operating pressure must never exceed 25 psig.
4. At initial fill and during heater startup and testing, check system thoroughly for any leaks. Repair all leaks before proceeding further.

## PART 11. START-UP PREPARATION (CONTINUED)

### **WARNING**

Eliminate all system leaks. Continual fresh make-up water will reduce heater life. Minerals can build up in the heat exchanger, reducing heat transfer, overheating heat exchanger, and causing heat exchanger failure.

5. The system may have residual substances that could affect water chemistry. After the system has been filled and leak tested, verify water pH and chlorine concentrations are acceptable.

### **CAUTION**

It is important that you purge the system of air to avoid damage to the heater.

#### D. PURGE AIR FROM WATER SYSTEM

1. Purge air from system:
  - a. Connect a hose to the purge valve and route hose to an area where water can drain and be seen.
  - b. Close the heater or system isolation valve between the purge valve and fill connection to the system.
  - c. Close zone isolation valves.
  - d. Open quick-fill valve on cold water make-up line.
  - e. Open purge valve.
  - f. One zone at a time, open the isolation valves. Allow water to run through the zone, pushing out the air. Run until no noticeable air flow is present. Close the zone isolation valves and proceed with the next zone. Follow this procedure until all zones are purged.
  - g. Close the quick-fill water valve and purge valve and remove the hose. Open all isolation valves. Watch that system pressure rises to correct cold-fill pressure.
  - h. After the system has operated for a while, eliminate any residual air by using the manual air vents located throughout the system.
  - i. If purge valves are not installed in system, open manual air vents in system

one at a time, beginning with lowest floor. Close vent when water squirts out. Repeat with remaining vents.

- j. Refill to correct pressure.

#### E. CHECK FOR GAS LEAKS

### **WARNING**

Before starting the Munchkin Contender, and during initial operation, smell near the floor and around the heater for gas odorant or any unusual odor. Remove heater front door and smell interior of heater enclosure. Do not proceed with startup if there is any indication of a gas leak. Repair any leak at once.

### **WARNING**

Propane heater only — Your propane supplier mixes an odorant with the propane to make its presence detectable. In some instances, the odorant can fade, and the gas may no longer have an odor. Before startup (and periodically thereafter), have the propane supplier verify the correct odorant level in the gas.

#### F. CHECK THERMOSTAT CIRCUIT(S)

1. Disconnect the two external wires connected to the heater thermostat terminals (low voltage terminal strip terminals 5 and 6).
2. Connect a voltmeter across these two incoming wires. Close each thermostat, zone valve and relay in the external circuit one at a time and check the voltmeter reading across the incoming wires.
3. There should NEVER be a voltage reading.
4. If a voltage does occur under any condition, check and correct the external wiring. (This is a common problem when using 3-wire zone valves.)
5. Once the external thermostat circuit wiring is checked and corrected if necessary, reconnect the external thermostat circuit wires to heater low voltage terminal strip. Allow the heater to cycle.

## PART 11. START-UP PREPARATION (CONTINUED)

### G. CONDENSATE REMOVAL

1. The Munchkin Contender is a high efficiency condensing heater, therefore, the unit has a condensation drain. Condensate is nothing more than water vapor, derived from combustion products, similar to an automobile when it is initially started. The condensation is slightly acidic (typically with pH of 3 to 5) and must be piped with the correct materials. Never pipe the condensate using steel, copper, brass or other materials that will be subject to corrosion. Plastic PVC or CPVC pipe are the only approved materials. A condensate filter, if required by local authorities, can be made up of lime crystals, marble or phosphate chips that will neutralize the condensate. This may be done by the installer or you may purchase a condensate neutralizer from Heat Transfer Products, Inc. (P/N N1100)
2. The Munchkin Contender is equipped with a 3/4" pipe connection that runs the condensation line to a local drain. It is very important that the condensate line is sloped away from the heater and down to a suitable inside drain. If the condensate outlet is lower than the drain, you must use a condensate removal pump, available at Heat Transfer Products (#554200). This pump is equipped with two leads that can be connected to an alarm or another type of warning device to alert residents of a

condensate overflow, which, if not corrected, could cause property damage.

3. If a long horizontal run is used, it may be necessary to create a second vent to prevent a vacuum lock in the condensate line. Do not expose the condensate to freezing temperatures.
4. Do not expose the condensate to freezing temperatures.
5. It is very important you support the condensation line to assure proper drainage.

### H. FINAL CHECKS BEFORE STARTING MUNCHKIN CONTENDER

1. Read Startup Procedures within this manual for proper steps to start heater. (See Startup Report to record steps for future reference.)
2. Verify the heater and system are full of water and all system components are correctly set for operation.
3. Fill condensate trap with water.
4. Verify electrical connections are correct and securely attached.
5. Inspect intake piping and exhaust piping for signs of deterioration from corrosion, physical damage or sagging. Verify intake piping and exhaust piping are intact and correctly installed per Venting section and local code.

## PART 12. START-UP PROCEDURE

### FOR YOUR OWN SAFETY READ BEFORE OPERATING

1. This appliance does not have pilot. It is equipped with an ignition device which automatically lights the burner. Do not try to light the burner by hand.
2. BEFORE OPERATING smell all around the appliance area for gas. Be sure to smell next to the floor because some gas is heavier than air and will settle on the floor.

### WHAT TO DO IF YOU SMELL GAS

- Do not try to light any appliance.
- Do not touch any electric switch; do not use any phone in your building.
- Immediately call your gas supplier from a neighbor's phone. Follow the gas suppliers' instructions.

- If you cannot reach your gas supplier, call the fire department.
3. Turn on gas shutoff valve (located inside of the Heater) so that the handle is aligned with the gas pipe. If the handle will not turn by hand, don't try to repair it, call a qualified service technician. Force or attempted repair may result in a fire or explosion.
  4. Do not use this appliance if any part has been under water. Immediately call a qualified service technician to inspect the appliance and to replace any part of the control system and any gas control which has been under water.
  5. The Munchkin Contender Heater shall be installed so the gas ignition system components are protected from water (dripping, spraying, rain, etc.) during appliance operation and service (circulator replacement, condensate trap, control replacement, etc.)

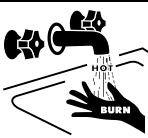
## PART 12. START-UP PROCEDURE (CONTINUED)

### A. OPERATING INSTRUCTIONS

Remove Munchkin Contender Heater cover. If you smell gas, **STOP**. Follow listed safety instructions. If you do not smell gas, follow the next steps.

1. Turn on all electric power to appliance.
2. Adjust the temperature setpoint of the Munchkin Contender Heater if desired. The factory default setting is 180°. If changes are necessary follow "Adjusting The Munchkin Setpoint" in this section.
3. Set the thermostat to the desired setting.
4. If the appliance fails to start, refer to the Troubleshooting section in the back of this manual.

**⚠ DANGER**



**⚠ DANGER** Water temperature over 125 degrees F. can cause severe burns instantly, or death from scalds. Children, disabled, and elderly are at highest risk of being scalded. See instruction manual before setting temperature at water heater. Feel water before bathing or showering! Temperature limiting valves are available.

### B. ADJUSTING THE SETPOINT

1. Before you can change the temperature from the factory setting of 180 degrees. You must make sure that none of the thermostats are calling for heat. The controller will not memorize a program setting while in a heating cycle. To adjust the temperature to the Munchkin Contender simply press in the **S3/Program** key for three seconds until you see a flashing **(C)** then an alternate value of (180). This number is the factory set point of the unit, which is 180 degrees. To change the temperature, simply push either the **S1/-** or **S2/+** on the display. The **S1/-** button will decrease the temperature while the **S2/+** will increase the temperature of the Munchkin. The temperature of the heater can be set as low as 50 Degrees and as high 180 Degrees. These ranges are your maximum and minimum ranges of the heater. In addition to changing the temperature you are also allowed to change three more settings in this model (1. Munchkin Contender Heater differential – 2.

Indirect setting (**with Vision System option**) – 3. Celsius to Fahrenheit measurement. Simply press in the **S3/Program** key to get to next value, the Munchkin Contender Heater differential setting will appear in the display ch and alternating value of 30. This allows the installer to adjust the activation of the burner based on the differential temperature setting of the Munchkin Contender Heater. The burner will not start until the outlet water temperature reaches a temperature that is equal to the temperature setting for the Munchkin Contender Heater, minus the differential EX: The Heater is set to heat at 180° F degrees and the differential is set at 30° F. The burner will not start until the outlet temperature of the system reaches 149° F degrees (180° – 30° F = 150° F). To adjust, press either **S1/-** (Decrease Value) or **S2/+** (Increase Value) Ranges 5° F to 30° F. Press the **S3/Program** key again and you will see the Indirect Setting de and an alternative value of 119 (with Vision Systems option) To adjust, press either **S1/-** (Decrease Value) or **S2/+** (Increase Value).

The final adjustment in this mode is the Fahrenheit to Celcius measurement. Press the **S3/Program** key again and you will see t and alternating value of F. To change value press the **S1/-** or **S2/+** to choose the correct measurement.

### C. STATUS MENU

Installers are also able to check the current status of the Munchkin Contender Heater parameters by pressing **S4/RESET** key for 3 seconds. Once activated, the display will show **d1** alternating value of the actual outlet temperature. Actual values are displayed for each function. To view the next value simply press the **S/4** key to go to the next displayed value. Listed below are the values which can be displayed. These values cannot be changed. To exit this menu, simply press **S3/Program** key to resume normal operation.

#### Function Value

- d1 — Actual Temperature from outlet sensor
- d2 — Actual Temperature from inlet sensor
- d3 — If using a standard mechanical control, the control will display **1** for closed **0** for open  
If the sensor is connected to the SuperStor Indirect Fired Water Heater it will measure the actual temperature. (Vision option.)

## PART 12. START-UP PROCEDURE (CONTINUED)

Function	Value
d4	— Not used
d5	— Actual Temperature from the outdoor sensor. (Vision option.)
d6	— Actual Fan speed multiplied by 10 (Example: If fan speed displayed is <b>410</b> RPM x 10 = 4100 actual fan speed)
d7	— Actual Ionization current read from Flame Rectification probe
d8	— Actual Status of the Central Heating Circulator Off = <b>0</b> , On = <b>1</b> . (Vision option.)
d9	— Actual Status of the Indirect Fired Circulator Off = <b>0</b> , On = <b>1</b> . (Vision option.)
d10	— Actual Status bus communication <b>co</b> = connected, <b>no</b> = not connected
d11	— Central Heating Set Point
d12	— Power On Hours in units
d13	— Total Central Heat Hours
d14	— Total Indirect/dhw Hours
d15	— Passed Ignition Attempts

### D. TEST MODE

This function is intended to simplify the gas valve adjustment if needed. Listed below are the

recommended limits on each Munchkin Contender and the Combustion Settings. Automatic modulation does not take place when the controller is in Test mode, only temperature limitation based on the Munchkin Contender Central Heating set point. The user will be allowed to increase or decrease the fan speed by pressing in either the **S1/-** or **S2/+** keys.

To activate the Test mode simply press the **S2/+** and **S3/Program** key together for 1 second. Once activated, you will see in the display **Ser** and the actual fan speed. The measurement of the combustion levels should always be taken at the highest and lowest fan speed. After 10 minutes, the Test mode stops automatically. To exit Test Mode press **S1/-** and **S2/+** key together for 1 second.

Fig. 12-1

COMBUSTION SETTINGS				
HIGH FIRING RATES and LOW FIRING RATES ON ALL MODELS				
	Natural Gas		Propane LP	
	low	high	low	high
Carbon Monoxide (CO %)	0–20 ppm	70 ppm–135 ppm	0–20 ppm	80 ppm–150 ppm
Carbon Dioxide (CO <sub>2</sub> %)	8½% – 9½%	8½% – 9½%	9½% – 10½%	9½% – 10½%

## PART 13: START-UP PROCEDURES WITH THE VISION 1 OPTION

The Vision I option allows the user to have one temperature for central heating and another temperature for the Super Stor Ultra Indirect Fired Water Heater. This allows the user to increase the temperature supplied to the Super Stor Ultra indirect water heater to get a fast recovery by prioritizing the flow at a higher temperature than may be needed for the Central Heating Circuits (this will require two separate circulators). Once the Super Stor Ultra Indirect is satisfied, the Vision I system will switch back to the Central Heating Circuit to continue to heat the living space at a temperature based on outside temperature. This gives you a higher comfort level and further increases the efficiency of the Munchkin Contender.

### A. PROGRAMMING THE VISION I OPTION

The Vision I option allows the installer to set system limits and the heat curve for the Munchkin Contender. These system limits should not be changed by the user. It is important to document your settings within this manual after you program the system parameters so this will be recorded for future reference.

### B. VISION 1 PROGRAM ACCESS

To start, press down and hold the **S/3** and **S/4** simultaneously for three seconds. You will notice that the display will change to **000**. Then, with your **S1/-** key on the display press down until you see **925**. This is the pass code. To confirm that



**PART 13: START-UP PROCEDURES WITH THE VISION 1 OPTION (CONTINUED)**

the pass code is correct, you will need to press and hold the **S3/Program** for 1 second to confirm. If the pass code is entered incorrectly, the controller program function will be cancelled and the control returns to normal operation. If the code is entered correctly, the control will switch off the gas valve and purge fan while showing a solid **---** in the display. The display will then show a **1** alternating to **de**. This first function verifies that the control will address the requirements of the Superstor Indirect Fired Water Heater.

**C. VISION 1 PROGRAM NAVIGATION**

Next you will have to press the **S/3** key to move through each function. To increase or decrease a value, you will need to press either the **S/1-** key or **S/2+** key to change the default values. If there is no key action for 1 minute, the display returns to normal operation. Changes are effective immediately but not directly stored until the **S/4** key is pressed down for 3 seconds then the new values are stored. Listed below are the variety of functions the installer can program into the Vision I System.

**CAUTION**

**The Munchkin Contender cannot be programmed while there is a call for heat.**

**NOTE:** See Chart 13-1 in Part 13 to set outdoor reset curve.

Default Function	Function Value	Description
1	de	<b>Not Applicable</b>
2	149°F	<b>Not Applicable</b>
3	160°F	Maximum Domestic Delivery Water Temperature Setpoint the Installer will program for SuperStor Indirect Fired Water Heater ( <b>Note:</b> Does not apply if used with Mechanical Control) <b>Range: 95°F to 160°F</b>
4	36°F	<b>Not Applicable</b>
5	7°F	Allows the installer to change the differential in the Indirect Fired Water Heater (Does not apply if used with a Mechanical Control) <b>Range: 1°F to 18°F</b>

Default Function	Function Value	Description
6	0 Min.	Allows the installer to change the Indirect Circulator Post Purge Time once the sensor is satisfied (Note: it is recommend that Circulator Post Purge Time be set no greater than 5 minutes). <b>Range: 0 to 60 minutes</b>
7	68°F	Outdoor temperature that you wish the central heating should be disabled—(warm weather shut-off) <b>Range: 41°F to 122°F</b>
*8	5°F	Allows the installer to change the Minimum Outside Design Temperature. <b>Range: -49°F to 32°F</b> (See Chart 13-1 to set outdoor reset curve)
*9	180°F	Allows the installer to change the Design Supply Water Temperature from the Munchkin based on the Minimum Outside Design Temperature <b>Range: 77°F to 180°F</b>
*10	68°F	Allows the installer to change the Maximum Outside Design Temperature for Central Heating. <b>Range: 95°F to 32°F</b>
*11	95°F	Allows the installer to change the Design Supply Water Temperature from the Munchkin based on the Maximum Outside Design Temperature. <b>Range: 32°F to 180°F</b>
12	68°F	Allows the installer to set the lowest temperature on the Munchkin for Central Heating. <b>Range: 32°F to 180°F</b>
13	0 Min.	Allows the installer to change the Central Heating Circulator Post Purge Time once the thermostat is satisfied. <b>Range 0 to 10 minutes.</b>

**PART 13: START-UP PROCEDURES WITH THE VISION 1 OPTION (CONTINUED)**

Default Function	Function Value	Description
14	30 Min.	Allows the installer to set the Maximum run time for the Indirect Fired Water Heater and the Minimum run time for Central Heating. <b>Range 0 to 60 Minutes</b>
15	0	Bus address (0=zone master 1-8 — cascade slave) (Not currently used.)
16	0	Interface Board Activation 0 = not active 1 = active WARNING: Never change the default setting without the Munchkin Interface Board installed.**
17	0	Interface Board Function 0 = Building Management 1 = Enables Tekmar Modulating control. (Consult with Tekmar to assure the Tekmar Control is compatible)
18	1	Step Modulation – Regulates the burner output in 6 steps in one-minute intervals. This reduces short cycling. 1 = on 0 = off
19	180°	Indirect heater set point (flow) Temperature default = 119° to 180°
20	1	Not applicable

**\* Central Heating Curve Function**

The central heating demand is detected when the room thermostat closes. When an outside sensor is also connected, the supply temperature will depend on the factory default central heating curve.

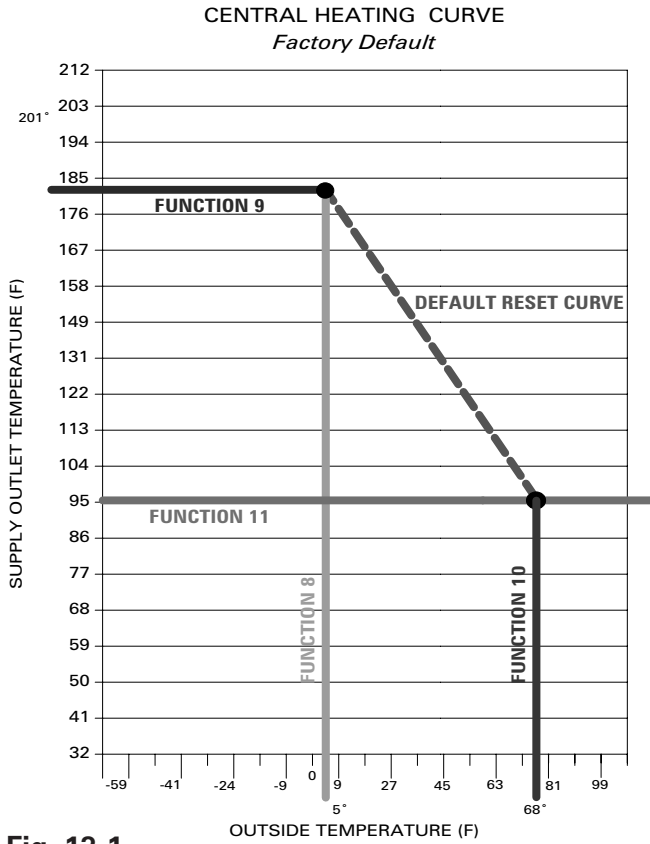
To set your heat curve you will have to set the following parameters

1. Minimum outside design temperature: **Function 8**
2. Design Supply water temperature at the minimum design outside temperature: **Function 9**
3. Maximum outside design temperature: **Function 10**
4. Design Supply water temperature at the maximum outside temperature: **Function 11**

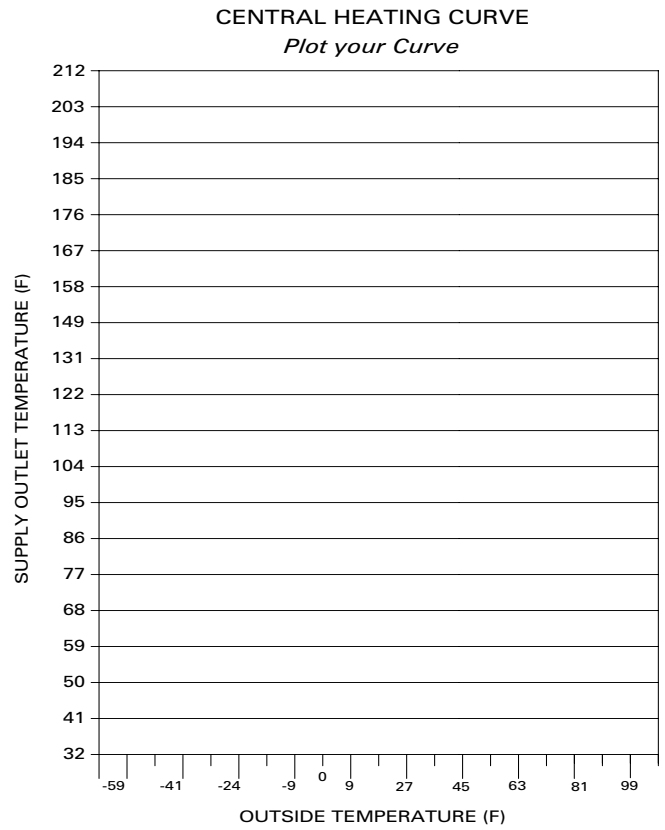
**NOTICE**

**It is important to note that the homeowner can adjust the heat curve down by adjusting the central heating temperature to a lower setting.**

**PART 13: START-UP PROCEDURES WITH THE VISION 1 OPTION (CONTINUED)**



**Fig. 13-1**



**Fig. 13-2**

CONTROL PROGRAM REFERENCE CHART		
Function	Default Setting	Programmed Setting
1	de	No change allowed
2	149 F	No change allowed
3	160 F	
4	36 F	No change allowed
5	7 F	
6	0 minutes	
7	68 F	
8	5 F	
9	180 F	
10	68 F	
11	95 F	
12	68 F	
13	0 minutes	
14	30 minutes	
15	0	
16	0	
17	0	
18	1	
19	180°F	

**Fig. 13-3**

## PART 14: TROUBLESHOOTING

### A. MUNCHKIN ERROR CODE

An error code may occur in the installation of the Munchkin Contender. This condition may lead to a lock out condition of the controller, which will need to be manually reset through the S4/Reset button. These temporary codes will help the installer correct the problem before going into a lock out condition, which will require a manual reset.

### B. HEATER ERROR

1. When an error condition occurs the controller will display an error code on the display module.
2. These error codes and several suggested corrective actions are included in Table 14-1.
3. In the case of E00, E13, and E14 this error, if uncorrected, will go into a fault condition as described in Paragraph C (Heater Fault).

### C. HEATER FAULT

1. When a fault condition occurs the controller will illuminate the red "fault" indication light and display a fault code in the format (Example: **F00**) on the display module.
2. Note the fault code and refer to Table 14-2 for an explanation of the fault code along with several suggestions for corrective actions.
3. Press the reset key to clear the fault and resume operation. Be sure to observe the operation of the unit to prevent a recurrence of the fault.

### WARNING

When servicing or replacing any components of this heater be certain that:

- The gas is off.
- All electrical power is disconnected

### DANGER

When servicing or replacing that are in direct contact with the heater water, be certain that:

- There is no pressure in the heater. (Pull the release on the relief valve. Do not depend on the pressure gauge reading).
- The heater water is not hot
- The electrical power is off

### WARNING

Do not use this appliance if any part has been under water. Improper or dangerous operation may result. Contact a qualified service technician immediately to inspect the heater and to repair or replace any part of the heater which has been under water.

### CAUTION

This appliance has wire function labels on all internal wiring. Observe the position of each wire before removing it. Wiring errors may cause improper and dangerous operation. Verify proper operation after servicing.

### CAUTION

If overheating occurs or the gas supply fails to shut off, do not turn off electrical power to the circulating pump. This may aggravate the problem and increase the likelihood of heater damage. Instead, shut off the gas supply to the heater at the gas service valve.

Table 14-1 : 925 Control Board ERROR Codes

Code	Description	Duration	Corrective Action
<b>E13</b>	Combustion Fan Speed Low. The heater combustion air fan speed less than 70% of expected.	60 Sec.	1. Check the combustion air fan wiring. 2. Replace the combustion air fan. 3. Replace the control board.
<b>E14</b>	Combustion Fan Speed High. The heater combustion air fan speed is more than 130% of expected.	60 Sec.	1. Check the combustion air fan wiring. 2. Replace the combustion air fan. 3. Replace the control board.
<b>PRO</b>	Water Pressure Switch Open	Until Corrected	1. Assure that the system pressure is above 10 psig. 2. Check for leaks in the system piping.
<b>FLU</b>	Blocked Vent Pressure Switch Open	Until Corrected	1. Assure that the vent is not blocked 2. Check the switch operation by applying a jumper. (If the switch is not functioning properly, replace it.)

**PART 14: TROUBLESHOOTING (CONTINUED)**

**Table 14-2: 925 Control Board FAULT Codes**

<b>Code</b>	<b>Description</b>	<b>Remedy</b>
<b>F00</b>	High Limit Exceeded.	<ol style="list-style-type: none"> <li>1. Check circulation pump operation</li> <li>2. Assure that there is adequate flow through the heater by accessing the status menu and assuring that there is less than a 50°F rise from the return thermister to the supply thermister.</li> <li>3. Check thermister reading on supply thermister. Replace switch if faulty.</li> </ol>
<b>F01</b>	Vent Temperature Limit Switch Exceeded.	<ol style="list-style-type: none"> <li>1. Push the red reset button on the vent temperature limit switch.</li> <li>2. Check the flue temperature during operation using a combustion analyzer.</li> <li>3. Replace the vent limit switch if faulty.</li> </ol>
<b>F02</b>	Interrupted or Shorted Supply (Outlet) Thermister.	<ol style="list-style-type: none"> <li>1. Check the electrical connection to the thermister on the outlet manifold.</li> <li>2. Replace thermister if necessary.</li> </ol>
<b>F03</b>	Interrupted or Shorted Return (Inlet) Thermister.	<ol style="list-style-type: none"> <li>1. Check the electrical connection to the thermister on the inlet manifold.</li> <li>2. Replace thermister if necessary.</li> </ol>
<b>F05</b>	Supply (Outlet) Temperature exceeds 230°F.	<ol style="list-style-type: none"> <li>1. Check circulation pump operation.</li> <li>2. Assure that there is adequate flow through the heater by accessing the status menu and assuring that there is less than a 50°F rise from the return thermister to the supply thermister.</li> </ol>
<b>F06</b>	Return (Inlet) Temperature Exceeded 230°F.	<ol style="list-style-type: none"> <li>1. Check circulation pump operation.</li> <li>2. Assure that there is adequate flow through the heater by accessing the status menu and assuring that there is less than a 50°F rise from the return thermister to the supply thermister.</li> </ol>
<b>F09</b>	No flame detected – The heater will make three attempts at ignition before the control goes into this lockout condition. *See spark electrode detail.	<ol style="list-style-type: none"> <li>1. Watch the igniter through the observation window provided.</li> <li>2. If there is no spark, check the spark electrode for the proper ¼" gap. Use 2 quarters together as a gauge to check gap distance.</li> <li>3. Remove any corrosion from the spark electrode and flame rectifier probe.</li> <li>4. If there is a spark but no flame, check the gas supply to the heater.</li> <li>5. If there is a flame, check the flame sensor.</li> <li>6. Check any flue blockage or condensate blocks.</li> </ol>
<b>F10</b>	Loss of Flame Signal – The heater will relight 4 times before the control goes into this lockout condition.	<ol style="list-style-type: none"> <li>1. Monitor the gas pressure to the unit while in operation.</li> <li>2. Assure that the flame is stable when lit.</li> <li>3. Check to see if the green light on the display module is out while the heater is running.</li> <li>4. If the green light doesn't come on or goes off during operation check the flame signal on the status menu.</li> <li>5. If the signal reads less than 1 microampere, clean the flame rectifier probe.</li> <li>6. If the flame rectifier probe continues to read low, replace it.</li> </ol>
<b>F11</b>	False Flame Signal – The heater will lock out if it senses a flame signal when there should be none present.	<ol style="list-style-type: none"> <li>1. Turn the gas off to the unit at the service valve.</li> <li>2. If the flame signal is still present replace the igniter.</li> <li>3. If the flame signal is not present after turning off the gas supply, check the gas valve electrical connection.</li> <li>4. If there is no power to the gas valve, remove the valve and check for obstruction in the valve seat or replace the gas valve.</li> <li>5. Turn the gas on at the service valve after corrective action is taken.</li> </ol>
<b>F13</b>	Combustion Fan Speed Low – The heater will lock out if it senses that the fan speed is less than 70% of expected rate for more than 60 seconds.	<ol style="list-style-type: none"> <li>1. Check the combustion air fan wiring.</li> <li>2. Replace the combustion air fan.</li> <li>3. Replace the control board.</li> </ol>
<b>F14</b>	Combustion Fan Speed High – The heater will lock out if the fan speed is more than 130% of expected rate for more than 60 seconds.	<ol style="list-style-type: none"> <li>1. Check the combustion air fan wiring.</li> <li>2. Replace the combustion air fan.</li> <li>3. Replace the control board.</li> </ol>
<b>F18</b>	Gas Valve Error	<ol style="list-style-type: none"> <li>1. Make sure the connector is correctly connected to the gas valve.</li> <li>2. Check the electrical wiring from the valve to the control board.</li> <li>3. Replace the low voltage wiring harness assembly.</li> <li>4. Replace control board.</li> </ol>
<b>F30</b>	Watchdog	Call factory for further assistance.
<b>F31</b>	Parameter Memory	Call factory for further assistance.
<b>F32</b>	Parameter Memory Write Error	Call factory for further assistance.
<b>F33</b>	Programming Error	Call factory for further assistance.

## PART 14: TROUBLESHOOTING (CONTINUED)

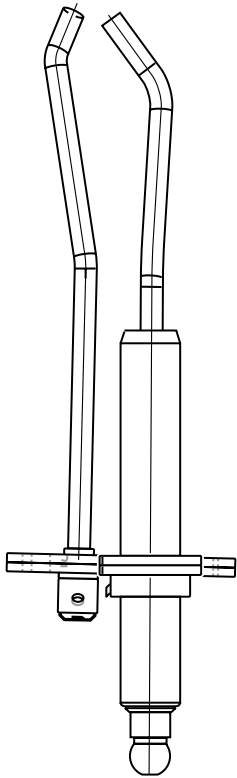


Fig. 14-2

NOTE: If receiving an F09 fault code, check the gap spacing between points on the electrode by holding two quarters together and sliding them through the gap. There should be a slight resistance.

### Resistance Tables

Outdoor Sensor (7250P-319)	
Outside Temperature (°F)	Resistance (ohms)
-22	171800
-13	129800
-4	98930
5	76020
14	58880
23	45950
32	36130
41	28600
50	22800
59	18300
68	14770
77	12000
86	9804
95	8054
104	6652
113	5522

Fig. 14-3

Heater Sensor (7250P-059)	Indirect Sensor (7250P-320)
Heater and Indirect Temperature (°F)	Resistance (ohms)
32	32550
41	25340
50	19870
59	15700
68	12490
77	10000
86	8059
95	6535
104	5330
113	4372
122	3605
131	2989
140	2490
149	2084
158	1753
167	1481
176	1256
185	1070
194	915
203	786
212	667

## PART 15: MAINTENANCE

### A. MAINTENANCE PROCEDURES

Periodic maintenance should be performed once a year by a qualified service technician to assure that all the equipment is in safe efficient operation. The owner can make necessary arrangements with a qualified heating contractor for periodic maintenance of the heater. Installer must also inform the owner that the lack of proper care and maintenance of the heater may result in a hazardous condition. The installer should discuss the contents of the User's Information Manual with the owner.

### **⚠ WARNING**

**BEFORE EACH HEATING SEASON** A trained and qualified service technician should perform the inspections as per the heater inspection and maintenance schedule in the back of manual. Failure to do so could result in death or serious injury.

**PART 15: MAINTENANCE (CONTINUED)**

**⚠ WARNING**

The combustion chamber insulation in this product contains ceramic fiber material. Ceramic fibers can be converted to cristobalite in very high temperature applications. The International Agency for Research on Cancer (IARC) has concluded, "Crystalline silica inhaled in the form of quartz or cristobalite from occupational sources is carcinogenic to humans (Group1).":

- Avoid breathing dust and contact with skin and eyes.
  - Use NIOSH certified dust respirator (N95). This type of respirator is based on the OSHA requirements for cristobalite at the time this document was written. Other types of respirators may be needed depending on the job site conditions. Current NIOSH recommendations can be found on the NIOSH website at <http://www.cdc.gov/niosh/homepage.html>. NIOSH approved respirators, manufacturers, and phone numbers are also listed on this website.
  - Wear long-sleeved, loose fitting clothing, gloves, and eye protection.
- Apply enough water to the combustion chamber lining to prevent dust
- Wash potentially contaminated clothes separately from other clothing. Rinse clothes washer thoroughly.

**NIOSH stated First Aid.**

- Eye: Irrigate immediately
- Breathing: Fresh air.

**B. COMBUSTION CHAMBER COIL CLEANING INSTRUCTIONS**

\*Before beginning this procedure, you must have on hand the following items:

- a nylon, stainless or brass brush (not steel)
- "Rydlyme" (recommended for best results) (available on line [www.rydlyme.com](http://www.rydlyme.com)) or "CLR" (available at most hardware stores)
- Gloves, eye protection

1. Shut down the Munchkin Contender by using the following steps:
  - a. Close the gas valve, shut down the unit and wait for the unit to be cool to the touch
  - b. Disconnect the condensate hose from the **outside** connection, (**not from the**

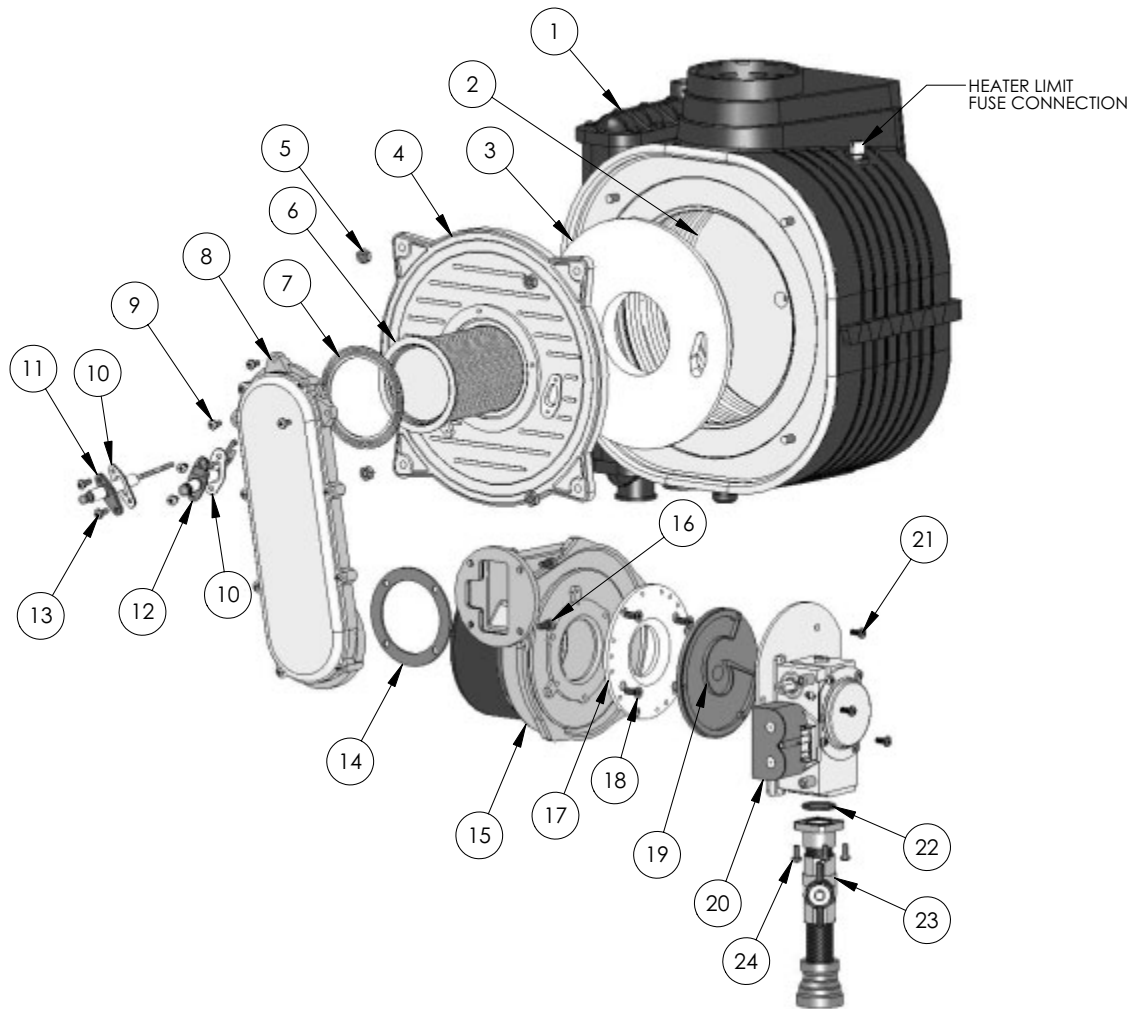
**Munchkin Contender side**), so the flow can be observed.

- c. Disconnect connections from the gas valve, spark electrode and flame rectification probe and combustion blower.
  - d. Remove the (4) screws on the aluminum 1/2" NPT connector on the gas valve.
  - e. Disconnect the wiring connected to the combustion blower motor.
  - f. Remove the (4) 10MM nuts from the burner plate assembly to access the coils.
  - g. Pull the entire burner plate assembly with blower still attached towards you, while removing or pushing aside any wiring to allow the removal of the assembly.
2. Using a spray bottle filled with the recommended product "RYDLYME" or "CLR", spray liberally on the coils, making sure the solution penetrates and funnels down through the condensate hose. If the condensate hose is blocked, let the chemical penetrate for at least 15 minutes or until it drains.
  3. Use the nylon, stainless or brass brush (do not use steel) and scrub coils to remove any buildup, then vacuum the debris from the coils. **WARNING: Follow precautions above**
  4. Spray the coils with clear water, making sure to confine the spray to the area being cleaned (Try to avoid getting the back ceramic wall of the unit wet). Flush the combustion chamber with fresh water. At this point, the Munchkin Contender should be ready to power back up.

Before powering up the Munchkin Contender follow the steps below

- a. Re-install the burner assembly
- b. Replace the (4) 10MM nuts to the burner plate
- c. Re-connect all wiring connections
- e. Replace the (4) screws on the aluminum 1/2" NPT connector on the gas valve. Turn the gas back on. (**IMPORTANT: CHECK FOR GAS LEAKS**)
- f. Re-set thermostats (**IMPORTANT: MAKE SURE EXHAUST VENT IS NO LONGER BLOCKED!**)
- g. Turn the Munchkin Contender back on and observe condensate flow.
- h. Re-connect the condensate hose to the outside connection.

**PART 15: MAINTENANCE (CONTINUED)**

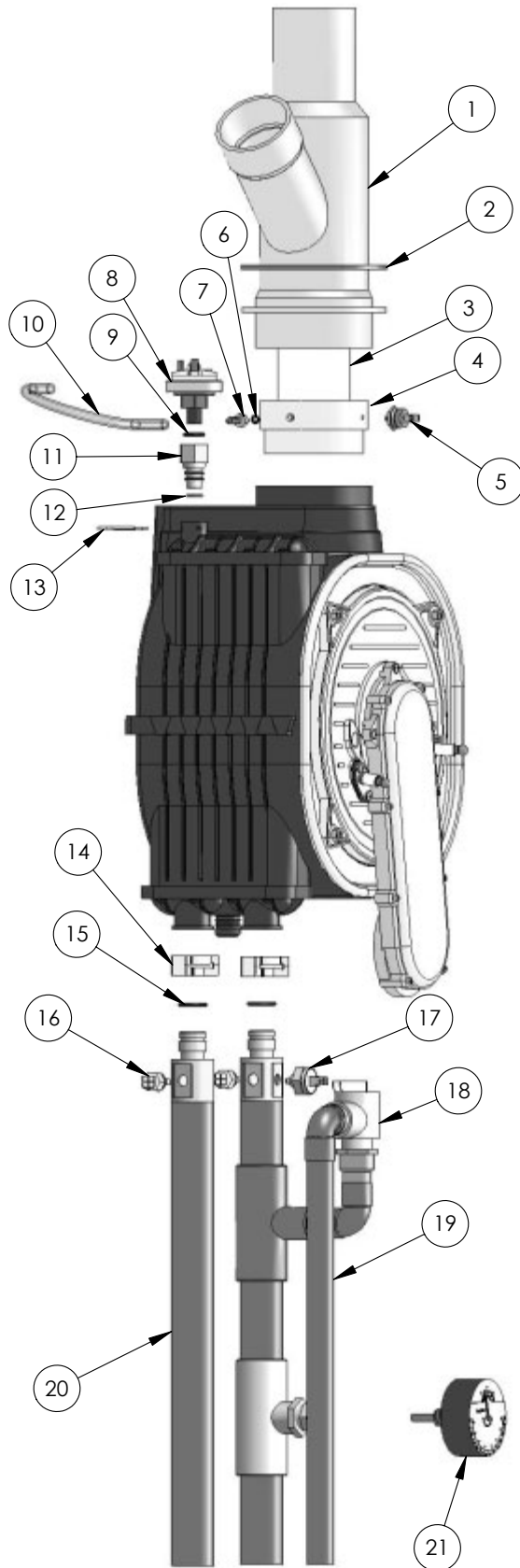


REPLACEMENT PARTS					
Item #	Description	Part #	Item #	Description	Part #
1	Composite Module	7500P-010 (MC50)	14	Gasket (Air Channel to Combustion Blower)	7500P-075
		7500P-012 (MC80)	15	Combustion Blower (w/Screws)	7500P-031
		7500P-014 (MC99/MC120)	16	Screws M5 x 14MM (Combustion Blower)	7250P-254
2	Ceramic Target Wall	7250P-160	17	Gas Valve Adapter Plate (w/Screws)	7250P-644
3	Burner Door Ceramic Refractory	7500P-076	18	Screws M4 x 12MM (Gas Valve Adapter Plate)	7500P-105
4	Burner Door (w/Nuts)	7500P-078	19	Gas Valve Swirl Plate	7500P-091 (MC50)
5	Nuts - M6 (Burner Door)	7500P-067			7500P-092 (MC80)
6	NIT Burner	7500P-015 (MC50)			7500P-093 (MC99/MC120)
		7500P-016 (MC80)	20	Gas Valve (w/Swirl Plate, Screws)	7250P-448 (MC50)
		7500P-017 (MC99/MC120)			7250P-449 (MC80)
7	Gasket (Burner)	7500P-074			7000P-862 (MC99/MC120)
8	Air/Gas Channel (w/Torx Screws)	7500P-079	21	Screws M4 x 18MM (Gas Valve)	7250P-716 (MC50)
9	Torx Screws (Air/Gas Channel)	7500P-068		Screws M4 x 19MM (Gas Valve)	7250P-717 (MC80)
10	Gasket (Flame Rec./Spark Electrode)	7250P-005		Screws M4 x 25MM (Gas Valve)	7250P-718 (MC99/MC120)
11	Flame Rectification Probe (w/Gasket)	7500P-039	22	O-Ring (Gas Valve Piping Assy)	7500P-094
12	Spark Electrode (w/Gasket)	7500P-040	23	Gas Valve Piping Assembly (w/O-ring, Screws)	7500P-095
13	Screws M4 x 8MM (Probe/Electrode)	7250P-069	24	Screws M4 x 12MM (Gas Valve Piping Assy)	7500P-099

Fig. 15-1



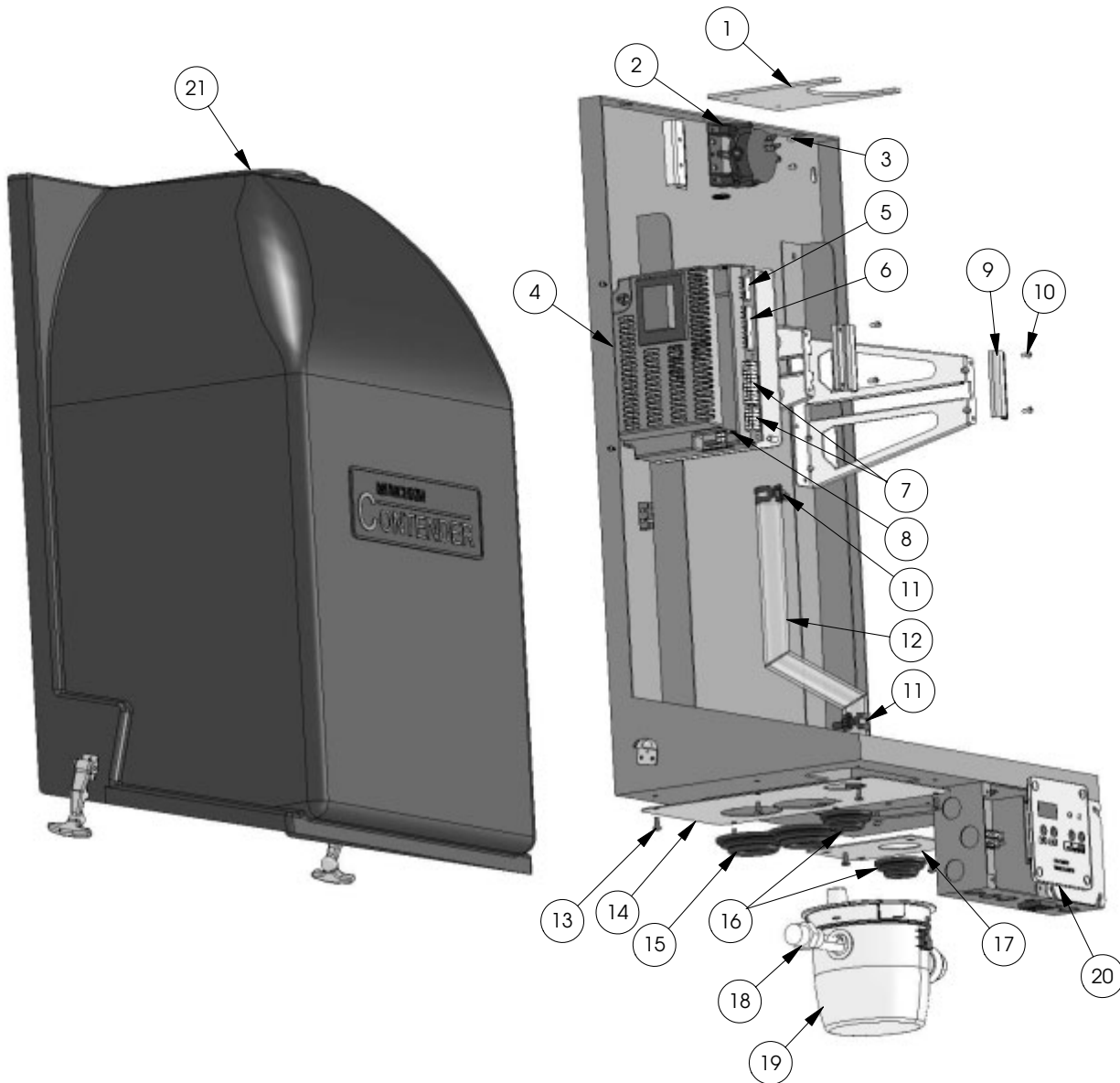
**PART 15: MAINTENANCE (CONTINUED)**



REPLACEMENT PARTS		
Item #	Description	Part #
1	Concentric Flue Outlet (w/Gasket)	7500P-025
2	Gasket (Concentric Flue Outlet)	7500P-008
3	PVC Pipe (2" Sch. 40 - 12" Long)	7500P-097
4	Flue Adapter	7500P-007
5	Flue ECO	7500P-002
6	O-Ring (S.S. Barbed Fitting)	7250P-152
7	S.S. Barbed Fitting	7250P-154
8	Water Pressure Switch	7250P-096
9	O-Ring (Water Pressure Switch)	7500P-124
10	Clear Tubing 3/16 ID x 5/16 OD	7000P-805
11	Water Pressure Switch Adapter	7500P-003
12	O-Ring (Water Pressure Switch Adapter)	7500P-100
13	Water Pressure Switch Clip	7500P-077
14	Supply/Return Manifold Clip	7500P-080
15	O-Ring (Supply/Return Manifold)	7500P-026
16	Thermistor	7250P-059
17	High Limit Sensor	7500P-033
18	Relief Valve	7250P-080
19	Supply Manifold Assembly (w/O-Ring, Relief Valve, Temperature/Pressure Gauge)	7500P-029
20	Return Manifold Assembly (w/O-Ring)	7500P-030
21	Temperature/Pressure Gauge	7500P-098

**Fig. 15-2**

**PART 15: MAINTENANCE (CONTINUED)**



REPLACEMENT PARTS					
Item #	Description	Part #	Item #	Description	Part #
1	Cover Filler Plate(w/Screws)	7500P-044 (MC50/MC80)	12	Condensate Hose (clear)	7500P-057
		7500P-032 (MC99/MC120)	13	Screws 8-32x3/8 (Filler/Gas Inlet Plate)	7500P-047
2	Blocked Vent Pressure Switch	7250P-150	14	Supply/Return Filler Plate (w/Screws)	7500P-022 (MC50/MC80)
3	Screws 8-32x3/8 (Blocked Vent Pressure Switch)	7500P-047			7500P-023 (MC99/MC120)
4	Control Board (w/Screws)	7250P-317	15	Lip Style Grommet - 1"	7500P-050
5	5 Pin Wiring Harness (location)	7500P-055	16	Lip Style Grommet - 1/2"	7500P-049
6	9 Pin Wiring Harness (location)	7500P-054	17	Gas Inlet Plate	7500P-043
7	Low Voltage Wiring Harness (location)	7500P-053	18	Condensate Float Switch	7500P-041
8	Screws # 6 x 1/2 - Control Board	7250P-480	19	Condensate Cup w/Engagement Switch	7500P-090
9	Clamp -Module to Bracket (w/Screws)	7500P-073	20	Control Board Display	7500P-058
10	Screws M4x6 (Clamp)	7500P-069	21	Contender Cover	7500P-027 (MC50/MC80)
11	CTB-27ST Spring Clamp (Condensate Hose)	7250P-012			7500P-028 (MC99/MC120)

**Fig. 15-3**

# HEATER START UP REPORT

Light Off Activities		Date completed _____
1) Fill the heating system	Check all piping and gas connections, verify they are all tight	
	Pressurize System (12-15 PSI)	____ PSI
	Add Water to prime condensate cup	
	What percentage of propylene glycol is installed in the system (0-50%)	____%
	Verify near heater piping is properly supported	
2) Check Gas Pipe	Leak test using locally approved methods (consult jurisdictional code book)	
	Check incoming gas pressure (3.5" to 14" W.C.)	____ in w.c. Static
	What is the 'drop' on light off (No more than 1" W.C.)	____ in w.c. Dynamic
3) Check Combustion	Check and adjust (if necessary) carbon dioxide content	____ % CO2 High Fire ____ % CO2 Low Fire
	Check and adjust (if necessary) carbon monoxide content	____ ppm CO High Fire ____ ppm CO Low Fire
4) Verify System Operation	Turn up thermostat to verify wiring connections	
5) Record Ionization Current	Check $\mu$ A reading at d7 on the status menu (see start-up section)	____ $\mu$ A High Fire ____ $\mu$ A Low Fire
6) Record System Settings	Record heating curve (with optional Vision One kit, record steps)	____ *8 ____ *9 ____ *10 ____ *11
7) Indirect water heater	Verify safety and operation of the Super-Stor Indirect water heater, record settings	____ de ____ dh
8) Convert the heater	If necessary convert the heater to the proper type of gas (always use proper kit)	
	Locate the stickers in the appropriate locations on the heater	
	Verify Combustion settings after gas conversion, Carbon Dioxide	____ % CO2 High Fire ____ % CO2 Low Fire
	Verify Combustion settings after gas conversion, Carbon Monoxide	____ ppm CO High Fire ____ ppm CO Low Fire
	Mail in the conversion registration	
<b>Notes:</b>		

# HEATER INSPECTION AND MAINTENANCE SCHEDULE

Inspection Activities	Date last completed			
	1st Year	2nd Year	3rd Year	4th Year*
<b>Piping</b>				
Near Heater Piping	Check heater and system piping for any sign of leakage, verify proper support			
Vent	Check condition of all vent pipe and joints			
Gas	Check gas piping, test for gas leaks and signs of aging, make sure all pipes are supported properly.			
<b>System</b>				
Visual	Do a full visual inspection of all system components			
Functional	Test all functions of the system (Heat, DHW, Safeties)			
Temperatures	Verify safe settings on Super-Stor indirect fired water heater or Anti-Scald Valve ( see part 12 for realted safety warnings)			
Temperatures	Verify temperature settings programmed into the heating curve ( See Part 13)			
<b>Electrical</b>				
Connections	Check wire connections, make sure they are tight			
Circuit breakers	Check to see that the circuit breaker is clearly labeled, exercise circuit breaker			
Switch and Plug	Verify ON/OFF switch and convenience plug are both functional			
Smoke and CO detector	Verify devices are installed and working properly, change batteries if necessary			
<b>Chamber and Burner</b>				
Combustion Chamber	Vacuum Combustion Chamber if Necessary			
Combustion Chamber	Check burner tube, and combustion chamber coils, clean according to maintenance section of manual			
Spark Electrode	Clean with scotch brite , Set gap at 1/4" (see Fig 14-2 Part 14 in Troubleshooting section)			
Flame Probe	Clean with scotch brite , Check ionization in $\mu$ A (d7 on status menu in Start-up Procedures) record high fire (3.8 to 4.2) and low fire (3.0 to 3.4)			

\* NOTE : CONTINUE MAINTENANCE BEYOND THE 4TH YEAR IS REQUIRED ON A YEARLY BASIS.

## HEATER INSPECTION AND MAINTENANCE SCHEDULE (CONTINUED)

Inspection Activities	Date last completed			
	1st Year	2 Year	3 Year	4 Year*
<b>Condensate</b>				
Condensate Neutralizer	Check condensate neutralizer, replace if necessary			
Condensate Cup	Disconnect condensate cup, clean out dirt, fill with water to level of outlet and re-install ( Note: you must verify the flow of condensate, making sure that the cup is connected properly during final inspection.)			
<b>Gas</b>				
Pressure	Measure incoming gas pressure (from 3.5" to 14" W.C.)			
Pressure Drop	Measure drop in pressure on light off (no more than 1" W.C.)			
Check gas pipe for leaks	Check piping for leaks, and verify they are all properly supported			
<b>Combustion</b>				
Check CO/CO2 Levels	Check levels of CO and CO2 in Exhaust (See start up section 12 fig 12-1 for ranges) record at high and low fire			
<b>Safeties</b>				
ECO (Energy Cut Out)	Check continuity on Flue and Water ECO, replace if corroded			
Water Pressure Switch	Check operation , check for signs of leakage, replace if corroded			
Thermistors	Check wiring, verify through ohms reading (see chart part 14 Fig. 14-3)			
<b>Final Inspection</b>				
Check List	Verify that you have completed the entire check list WARNING: FAILURE TO DO SO COULD RESULT IN DEATH OR SERIOUS INJURY.			
Homeowner	Review, with the homeowner what you have done			

\* NOTE : CONTINUE MAINTENANCE BEYOND THE 4TH YEAR IS REQUIRED ON A YEARLY BASIS.



## MAINTENANCE NOTES

